



HI-TECH AND EFFICIENCY FOR YOUR CROPS



Haifa

SERIE DEF

EN 





TRAILER FOR MINERAL FERTILIZER

Description:

Spreader for mineral fertilizer of 2.5 or 5 m³. Suitable for a surface or localized underground distribution of pellets and granulated.







Watch the video

<p>FULL RANGE</p> <ul style="list-style-type: none"> Up to 30 different models approved for Spain. The widest range of equipment in the market for compost or inorganic fertilizers spreading onto vineyard, fruit trees and open fields. 	<p>EXCLUSIVITY</p> <ul style="list-style-type: none"> The first and unique fertilizer spreader with 'automatic coupling integral system' (Option) to connect and disconnect the machine from the tractor cab in 4 seconds. 	<p>MULTIPURPOSE</p> <ul style="list-style-type: none"> Different accessories are available to distribute the selected fertilizer according to your crops. A configuration according to your needs.
<p>PRODUCTIVITY</p> <ul style="list-style-type: none"> Magnificent work in any type granulated fertilizer and pellet. High manoeuvrability. Stable and homogenous dosage regardless of the RPM or tractor speed. 	<p>DURABILITY</p> <ul style="list-style-type: none"> All models equipped with hydraulic torque limiter against overstrain on the drive belt. Low maintenance (no lubrication in its essential parts). Components and materials of high quality and first brands. 	<p>EASINESS</p> <ul style="list-style-type: none"> All models are designed for simple and intuitive operation. Fully hydraulic operation in all its functions.

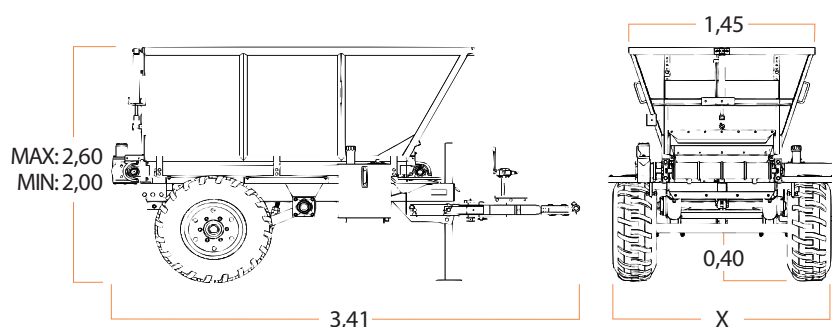
STANDARD EQUIPMENT

- Hydraulic parking brake.
- Working depth adjusting pin.
- Hydraulic adjustment of working depth and transport height.
- Torque limitation security valve on the driving belt.
- Hydraulic driving belt speed regulator (normal and inverted gear).
- Lights signaling bar.
- Rear door (automatic opening and closing).
- 4-ply conveyor belt with triple guide.
- Standing support foot adjustable in height.
- Turning draw bar (allows turns up to 90°).













REF.	DESCRIPTION	HOOPER			TIRE		X	kg	
		TYPE	m3	MTMA (kg)	Ø mm	TYPE			
DEF-4525-E	Fertilizer 2,5m3 / Electrical Cabin  X2 	Standard 	2,5	3100	805	7,50 x 16"	1,5	1175	45 Hp

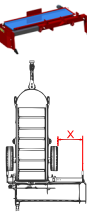



ACCESSORIES AND OPTIONS

	REF.	DESCRIPTION		OBSERVATIONS
	PA-T	Tractor Rear Assembly plate for articulated drawbar		Complete annex 3 completely
	SSC-F	Simple subsoiler		
	DS12-F	Double subsoiler		Normal fix Working width 1200 mm
	DS-V-F			Adjustable vibrator and width Working width 1200 to 1600 mm
	DSC-C14	Doble subsoiler with belt		Narrow 1400 to 1800 mm Manual Extension
	DSC-C14H			Hydraulic width adjusting
	DSC-C16H			Width 1600 to 2000mm Hydraulic width adjusting
	DSL503F	Right subsoiler with lateral Distributor discharge band and hydraulic extension		Short (x 50 cm max)
	DSL753F			Medium (x 75 cm max) Electric cabine 
	DSL103F			Long (x 100 cm max)
	TS-SUB	Cover furrows		Unit
	SON	Sonar *Available for machines with electric control		
	C-TFT	Camera + color screen 8"		For cab rear view
	K-EPCR	Proportional solenoid valve kit, electronic revolution counter and potentiometer		



Industrias David S.L.U

Polígono Industrial Urbayecla II.
Calle Médico Miguel Lucas s/n.

CP: 30510 Yecla, Murcia. Spain.

Tel: + 34 968 718 119

Fax: + 34 968 795851

info@industriasdavid.com

id-david.com



Follow us :



Región de Murcia



Unión Europea



AGRITECHMURCIA
SPAIN

ISO 9001
ISO 14001

BUREAU VERITAS
Certification



PYME INNOVADORA

Válido hasta el 31 de diciembre de 2019

