

# X-TREME

EN

*Single-edged frame equipped with in-row weeder and adaptable to the front of any tractor*



VITI

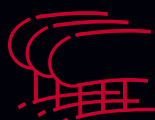

SETO



ARBO



**DAVID**  
SMART FARMING SOLUTIONS

SERIE

# X-TREME



**Single-edged frame equipped with in-row weeder and adaptable to the front of any tractor.** Ideal for working in plantations with slopes, ridges or terraces. It adjusts millimetrically to the terrain thanks to its flotation system and the multi-positional support wheel.

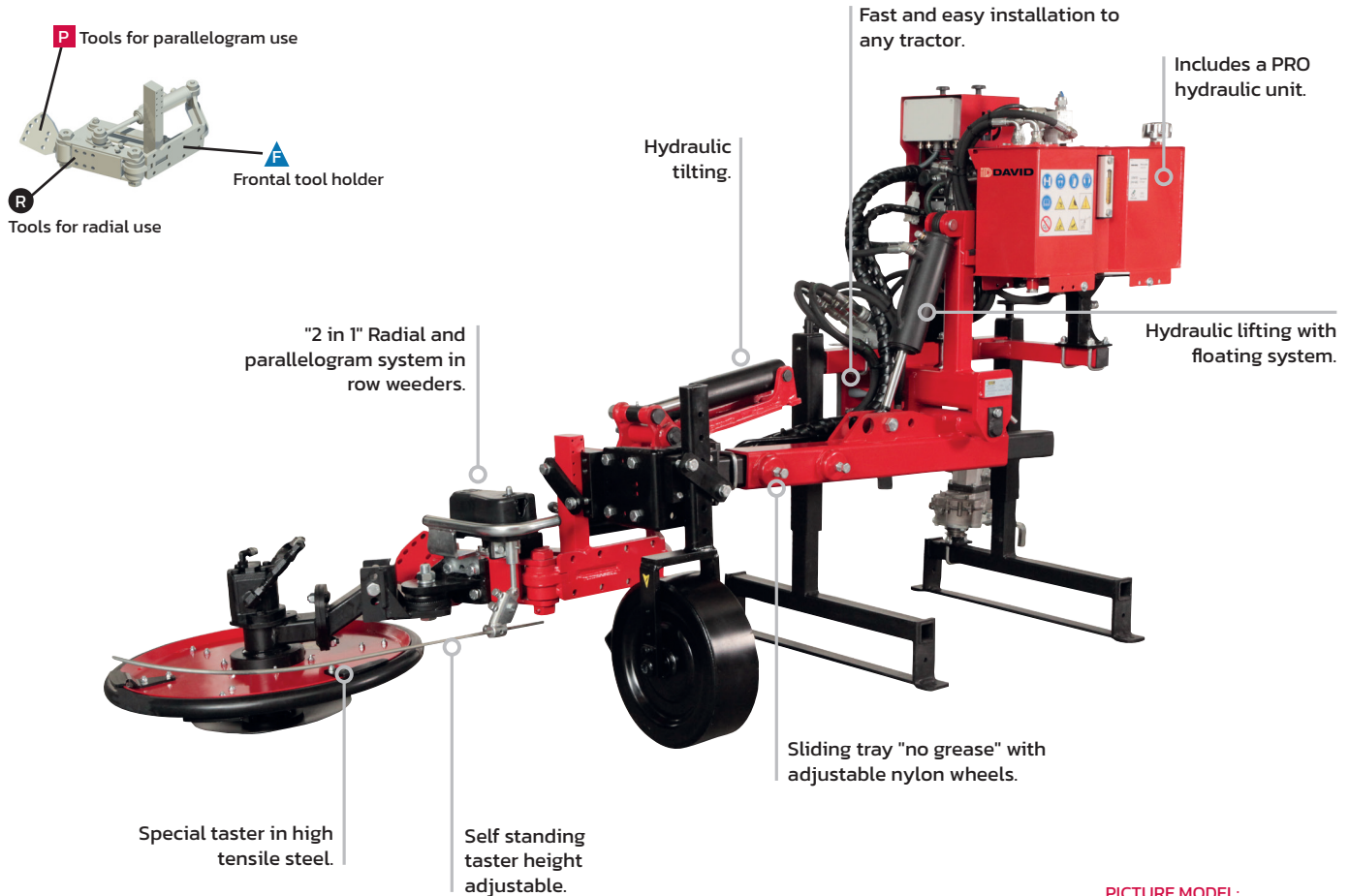

PICTURE MODEL:  
CFM-IA + GS50H-9-D



## Versatility

- The widest range of products and accessories on the market. A custom configuration to suit your needs.
- Different tools that allow both surface and tillage works up to 20 cm deep.
- The ID-CONTROL joystick allows to control all the machines manufactured by ID David and equipped with the ID-PLUS or ID-MICRO technology.

## Reliability

- Components and materials of high quality from certified manufacturers.
- Heavy duty frame and robotic welding.
- Great visibility of the rows.
- Experience in the manufacture of electrohydraulic undervine weeders since 1974.

## Exclusivity

- The exclusive undervine weeder that combines the "parallelogram-radial" movement.
- Faster, safer and endowed with unmatched versatility thanks to its triple tool holder.
- Opportunity to work between plants starting from 1 cm diameter thanks to our adjustable and progressive electronic sensor, the arm is moving at the right time to save the plant.

## Safety

- As standard all models are fitted with an exclusive safety locking system in case of faults.
- Enables route deviations up to 30 cm in the plantation/rows.
- Our equipment incorporates easy, comfortable and safe tool replacement systems.

## Effectiveness

- Time is valuable, it is possible to work up to 8 km/h with a standard soil conditions.
- The easy adjusting of hydraulic pressure of the in-row weeder assure a great work in any type of soil.
- The long hydraulic extension allows to work on large crown trees.
- Pivoting system for a perfect adjustment to the ground.

## Sustainability

- Ecological alternative to the use of herbicides.
- The low power required allows the use of small tractors with a lower carbon footprint.
- Improves the structure and porosity of the soil.

## Standard Equipment

- Includes a PRO hydraulic unit.
- Electrohydraulic extension.
- Floating and surface adaptable wheel.
- Legs with spindle for height adjustment (easy coupling to tractor).
- Electrohydraulic tilting.
- Standard coupling part to tractor.
- Quick coupling kit for power tools.
- Electrohydraulic lifting (floating or double effect).
- Electro hydraulic in row weeder.
- Anti-shock sensor protector.
- Hydraulic pressure regulator.
- Tool kit for sensor regulation.
- Arm "D" and blade manufactured in boron steel.



## Remote control type

### ID-PLUS

- Includes ID-CONTROL multifunction joystick.
- Includes ON-OFF of powered tools.
- Includes an electronic microcontroller: allows software updates at any time.
- Up to 2 additional electro-hydraulic functions.
- Includes a modular electro-hydraulic system: it allows to increase the number of electro-hydraulic functions.

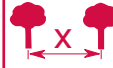

### ID-MICRO

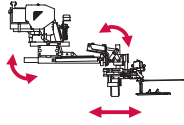
- ! NOT included the ID-CONTROL multifunction joystick.
- Only for customers who already have the ID-CONTROL multifunction joystick.
- Includes ON-OFF of powered tools.
- Includes an electronic microcontroller: allows software updates at any time.
- Up to 2 additional electro-hydraulic functions.
- Includes a modular electro-hydraulic system: it allows to increase the number of electro-hydraulic functions.

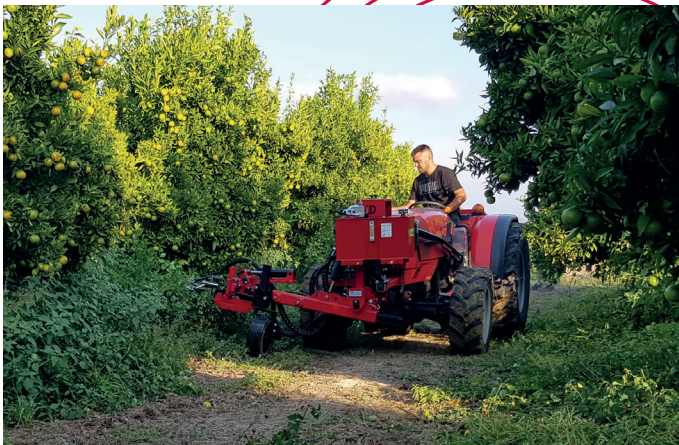
			ID-PLUS 	ID-MICRO 
<b>X-TREME</b>	cm	m	REF.	REF.
<b>1 IN ROW WEEDER</b> 	65	≥ 3,00	CFM-IA-1	CFM-IA-2



## Technical details



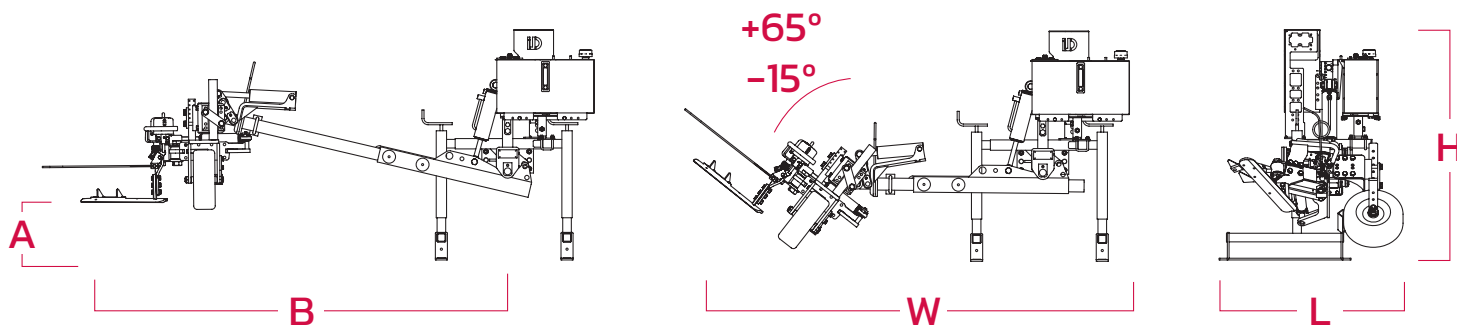

		A	B			L	W	H
<b>X-TREME</b>	REF.	m	m	kg	HP	m	m	m
<b>1 IN ROW WEEDER</b>	CFM-IA	0,50	1,75-2,70	440	50	1,20	2,00	1,30



## Tractor mounting





## Tractor connection and assembling

			
STANDARD	REF. CMT-17	REF. CMT-19	REF. CMT-18



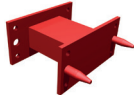







## Chassis

### Accessories and Options

	DESCRIPTION	OBSERVATIONS	REF.
	Plate for front tractor coupling	It will be supplied only if the corresponding form has been correctly filled out	PA-F
	3 Points linkage	Front 3P or reversible tractor	T3P-10

## Undervine weeders

### Accessories and Options

	DESCRIPTION	OBSERVATIONS	REF.
	Hydraulic power PRO unit 22L with pump 27L Adaptable to 3 PT	Replaces the standard hydraulic power unit Recommended for +4m tractors without front PTO	CPRO-O-T-S
	Standard oil cooler	Adaptable to PRO hydraulic power plant	Intake 12V A15-01-PRO
	Pressure filter kit + oil cooler	Replaces hydraulic power plant .	Intake 12V Tractor plugs connection.  KFP-O3
	Grass bend down system		Right STH-D
	Ultrasensible kit for sensitive sensor	Ideal vineyards $\leq 1$ cm	Unit KU-1
	Electrohydraulic kit for quick-connection (connection-disconnection)	In row weeder connection-disconnection	Right KER-IA-D
	Kit ID STAR 2 discs		Right KIA-S2-D
	Extra price ID-STAR (3rd disc)		Right ID-ST23-D



## Undervine weeders







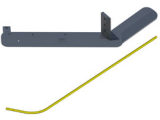

### Tools for PARALLELOGRAM USE

	Kit ID-ROLL Ø600	Adaptable to in-row weeder	Right KIA-R6-D
--	------------------	----------------------------	-------------------

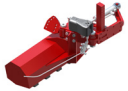
## Undervine weeders

### Tools for RADIAL USE

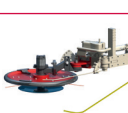
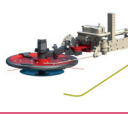
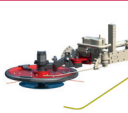
	DESCRIPTION	OBSERVATIONS	REF.
	Kit right weeding blade + sensor rod	Cut 49 cm	RCI49D
		Standard 55 cm	RCI55D
		Long 65 cm	RCI65D
	Kit right weeding blade + sensor rod	Recommended Reinforced Cylinder	Extra long 83 cm RCI83D
	Kit weeding blade type Boomerang + sensor rod	85 cm (65E + 20I cm)	RB6520D
		120 cm (65E + 55I cm)	RB6555D

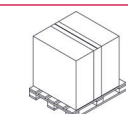
	DESCRIPTION	OBSERVATIONS		REF.
	Kit weeding blade made by Tugstene + sensor rod	Right	Standard 55 cm	RCHD55D
	Retractable extra cleaner blade "V" for blade		Right	EV-D
	Blade shovel		Right	VO-D
	Mower head 600 mm	Recommended oil cooler and reinforced cylinder		CT600D
	Kit Rotary hoe Ø300mm + sensor rod *Possibility of simultaneous use with weeding blade (not included)	Recommended oil cooler and reinforced cylinder	Right	RA30-9-D
	Kit Rotary hoe Ø400mm + Sensor rod *Possibility of simultaneous use with weeding blade (not included)	Recommended oil cooler and reinforced cylinder	Right	RA40-9-D
	Kit string mower Ø400mm + Sensor rod + String reel	Recommended oil cooler	Right	GS40H-9-D
	Kit string mower Ø500mm + Sensor rod + String reel	Recommended oil cooler	Right	GS50H-9-D
	Kit string mower Ø600mm + Sensor rod + String reel	Recommended oil cooler	Right	GS60H-9-D
	Kit string mower Ø800mm + Sensor rod + String reel	Recommended oil cooler	Right	GS80H-9-D
	Kit for modification of string mower with boron steel blades	Only available for new machine		KSGSH-D
	Square string spool	for mower	45 m	BHN-03
	Packaging	Basic		EMB-1
		Airfreight- oceanfreight		EMB-3

**Ideal products and services that inspire trust, quality, experience and excellence**

Specialized and customized agricultural machines with an attractive design and increasing digitalizations. Our products are oriented towards a biological, environment-friendly and precision farming.



**INDUSTRIAS DAVID S.L.U.**  
C/ Médico Miguel Lucas s/n  
CP: 30510, Yecla, Murcia-Spain  
Tel.: +34 968 718 119  
[info@id-david.com](mailto:info@id-david.com)

**Connect with us.**  
[instagram.com/iddavid\\_official](https://www.instagram.com/iddavid_official)  
[twitter.com/IDdavidslu](https://twitter.com/IDdavidslu)  
[facebook.com/industriasdavid](https://www.facebook.com/industriasdavid)  
[linkedin.com/company/id-david](https://www.linkedin.com/company/id-david)  
[youtube.com/industriasdavid](https://www.youtube.com/industriasdavid)

[www.id-david.com](http://www.id-david.com)

