

X10-TILLER

EN

*Semichisel spring frame with
hydraulic extension*



SERIE

X10-TILLER



Semichisel spring frame with hydraulic extension. Designed for soil tillage in vineyards and orchards.

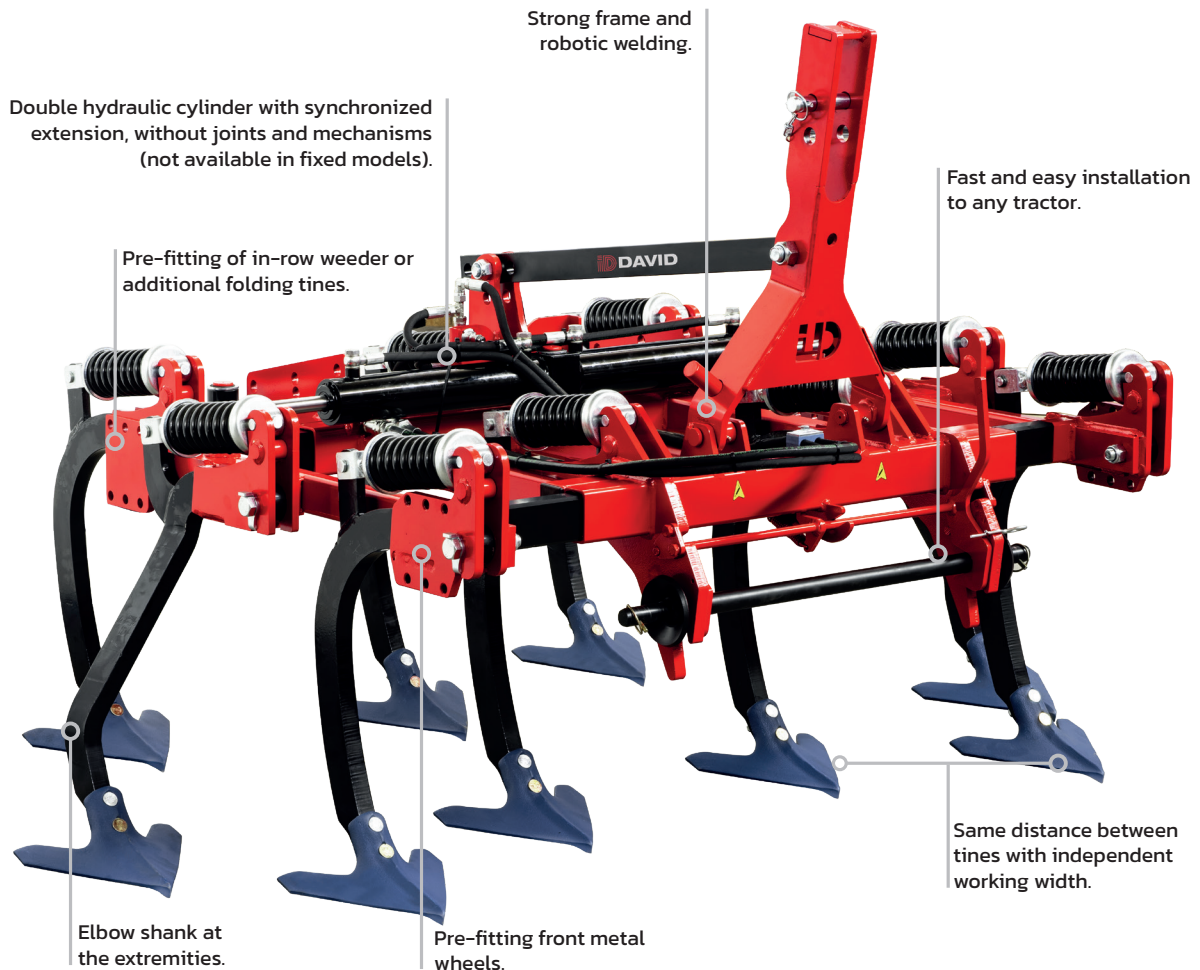

PICTURE MODEL:
CXH-9



Versatility

- A multitude of accessories available.
- Complete range. A configuration according to your needs.
- Up to 15 different models focused on soil working in vineyards and fruit trees.

Reliability

- The reinforced structure, hydraulically width adjustable, and the special tines enable to work with different types of ploughshare.
- Components and materials of high quality from certified manufacturers.
- Manufacturing experience since 1970.
- The maintenance is reduced to a minimal due to the total absence of joints and ball joints as well as the heavy duty width extensions.

Exclusivity

- The special position of the tines makes possible to work always at the same distance between them, whether the cultivator is completely extended or narrowed, avoiding jamming.

Safety

- Our equipment incorporates easy, comfortable and safe tool replacement systems.
- All models are designed for a safe, simple and intuitive use.

Effectiveness



- Time is valuable, it is possible to work up to 12 km/h with a standard soil conditions.
- Great work on every type of soil.
- Working depth of up to 25 cm.

Sustainability

- Ecological alternative to the use of herbicides
- Our painting is lead-free and without toxic pigments.
- Improves the structure and porosity of the soil.

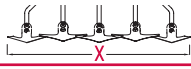

Standard Equipment

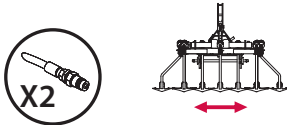
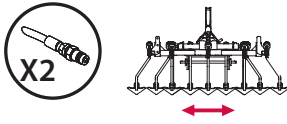
- Kit of Shank + Spring + Plowshare DAVID by Bellota.
- Elbow shank at the extremities.
- Pre-installation barb rake, roller and front metal wheels.
- Pre-installation in row weeder or additional folding arms.
- Double hydraulic cylinder onto extensions (not available for fixed frame model).
- Standard boron steel plowshare, hardness 50Hrc.
- Quick coupling.

			
X10-TILLER	ud	m	REF.
FIX 	3	0,90	CXF-3
	5	1,40	CXF-5
HYDRAULIC WIDTH ADJUSTABLE 	7	1,70-2,10	CXH-7
	7	1,85-2,25	CXH-7A
	9	1,90-2,50	CXH-9
	9	2,05-2,65	CXH-9A
	11	2,45-3,05	CXH-11
	11	2,60-3,20	CXH-11A
HYDRAULIC WIDTH ADJUSTABLE 2 FOLDING ARMS 	1+9+1	1,90-3,00	CXH-9/11
	1+9+1	2,05-3,15	CXH-9/11A





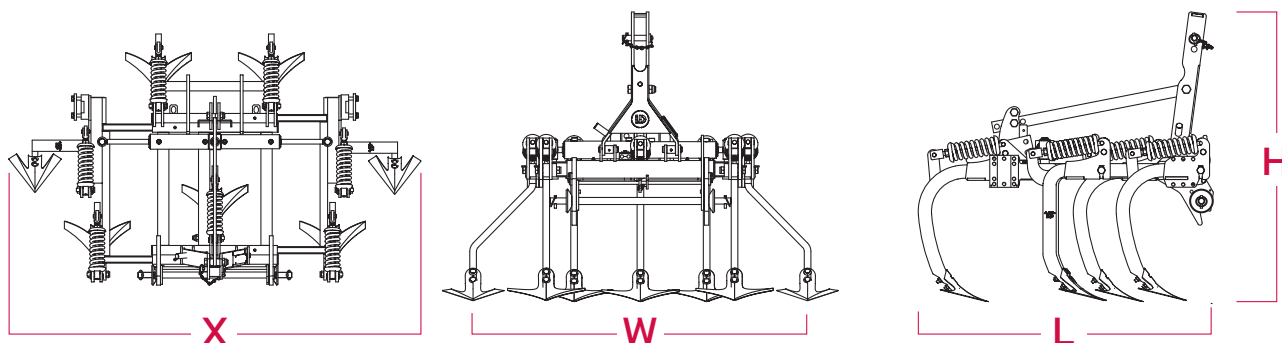

Technical details

X10-TILLER		X			L	W	H
		m	kg	HP	m	m	m
FIX	CXF-3	0,90	140	25	1,20	0,55	1,30
	CXF-5	1,40	210	35	1,20	1,05	1,30
HYDRAULIC WIDTH ADJUSTABLE	CXH-7	1,70-2,10	385	50	1,35	1,35	1,30
	CXH-7A	1,85-2,25	390	50	1,35	1,50	1,30
	CXH-9	1,90-2,50	450	65	1,45	1,55	1,30
	CXH-9A	2,05-2,65	455	65	1,45	1,70	1,30
	CXH-11	2,45-3,05	535	70	1,45	2,10	1,30
	CXH-11A	2,60-3,20	540	70	1,45	2,25	1,30
	CXH-13	2,95-3,55	610	90	1,45	2,60	1,30
HYDRAULIC WIDTH ADJUSTABLE 2 FOLDING ARMS	CXH-9/11	1,90-3,00	545	80	1,45	1,55	1,30
	CXH-9/11A	2,05-3,15	550	80	1,45	1,70	1,30



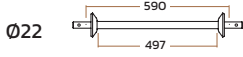

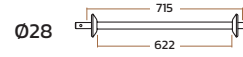

Drawbar





S Standard
 • Optional
 (Replace standard)

					
		REF. BE-2259	REF. BE-2271	REF. BE-2871	REF. BE-2887
FIX CULTIVATOR	CXF-3	S			
	CXF-5		•	S	
HYDRAULIC WIDTH ADJUSTABLE CULTIVATOR	CXH-7		•	S	
	CXH-7A		•	S	
	CXH-9		•	S	•
	CXH-9A		•	S	•
	CXH-11		•	S	•
	CXH-11A		•	S	•
	CXH-13		•	•	S
CULTIVATOR HYDRAULIC WIDTH ADJUSTABLE 2 FOLDING ARMS	CXH-9/11		•	S	•
	CXH-9/11A		•	S	•

Cultivator

Accessories and Options

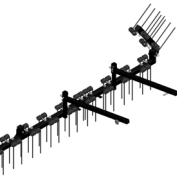
📷	DESCRIPTION	OBSERVATIONS		REF.
	Wide plow blade with rib 330x8mm + screws	Standard included	Unit	GA-1
	Plow blade with rib 275x8mm + screws		Unit	GN-1
	Double coil tines 70x8mm + screws		Unit	CM-1
	Supplementary wings 280x8mm + screws	Adaptable to fits in double coil tines	Unit	AL-1
	Dumpers + screws		Right	R14-D
			Left	R14-I
	Boot+chisel+flat grid 400mm	Adaptable accessory to arm	Unit	BFR400
	In row weeder breaker	Adaptable through elbow arm	Right	IMD
			Left	IMI
	Cultivator reinforced spring	Replace standard spring	Unit	MRC
			Extra	Unit
	Extra wide folding tine (+19 cms)	CXH7 - CXH9 - CXH11 - CXH13 * to consult for CXF3 - CXF5	Right	BAE-D
	*Included as standard CXH-9/11		Left	BAE-I
	Extra wide folding tine (+27 cms)	CXH7A - CXH9A	Right	BAA-D
	*Included as standard CXH-9/11A		Left	BAA-I
	Hydraulic 3 point hitch	Directly to the tractor		TH-DT
	Extendable roller Ø27cm	0,97 - 1,35 m	CXF3-CXF5	R1
		1,17 - 1,57 m	CXH7-CXH7A	R2
		1,56 - 2,36 m	CXH9-CXH9A CXH9/11-9/11A	R4
		1,76 - 2,76 m	CXH11 / 11A	R5
		2,31 - 3,31 m	CXH13-CXH13A	R6
		*Adjustable in height and width		
	Roller Ø40cm fix helical	0,82 m	CXF3	RF0
		1,05 m	CXF5	RF1
		1,40 m	CXH7-CXH7A	RF2
		1,75 m	CXH9-CXH9A CXH9/11-11A	RF4
		2,25 m	CXH11-CXH11A	RF5
		*Height adjustable	2,75 m	CXH13-CXH13A

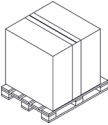
📷	DESCRIPTION	OBSERVATIONS		REF.
	Pair of smooth metallic wheels frontal mounting	Adjustable in height	Not available for CXF-3	RMD-P
		1,75 m		TT175
	Rear plank + Arms + Chains	2,25 m		TT225
		2,50 m		TT250
		2,75 m		TT275
	Floating barb rake	0,88 m	CXF3	RPF3
		0,88 - 1,46 m	CXF5	RPF5
		1,48 - 2,06 m	CXH7-CXH7A	RPF7
		1,64 - 2,36 m	CXH9-CXH9A	RPF9
		2,24 - 2,96 m	CXH11-CXH11A	RPF11
		2,70 - 3,41 m	CXH13-CXH13A	RPF13
	Adapted barb rake behind the roller	0,88 m	CXF3	RP3
		0,88 - 1,46 m	CXF5	RP5
		1,48 - 2,06 m	CXH7-CXH7A	RP7
		1,64 - 2,36 m	CXH9-CXH9A	RP9
		2,24 - 2,96 m	CXH11-CXH11A	RP11
		2,70 - 3,41 m	CXH13-CXH13A	RP13
	Packaging	Basic		EMB-1
		Airfreight- oceanfreight		EMB-2

Strategic alliancesm, our key to competitiveness

Consolidating knowledge and innovation as driver of our smart growth. We rely on strategic collaboration with universities, polytechnics, research centers, clusters, business associations and experts who enrich our knowledge and our ecosystem.



INDUSTRIAS DAVID S.L.U.
C/ Médico Miguel Lucas s/n
CP: 30510, Yecla, Murcia-Spain
Tel.: +34 968 718 119
info@id-david.com

Connect with us.
[instagram.com/iddavid_official](https://www.instagram.com/iddavid_official)
twitter.com/IDdavidslu
[facebook.com/industriasdavid](https://www.facebook.com/industriasdavid)
[linkedin.com/company/id-david](https://www.linkedin.com/company/id-david)
[youtube.com/industriasdavid](https://www.youtube.com/industriasdavid)

www.id-david.com

