

# RUNDER

EN

*Reversible mulching roller*

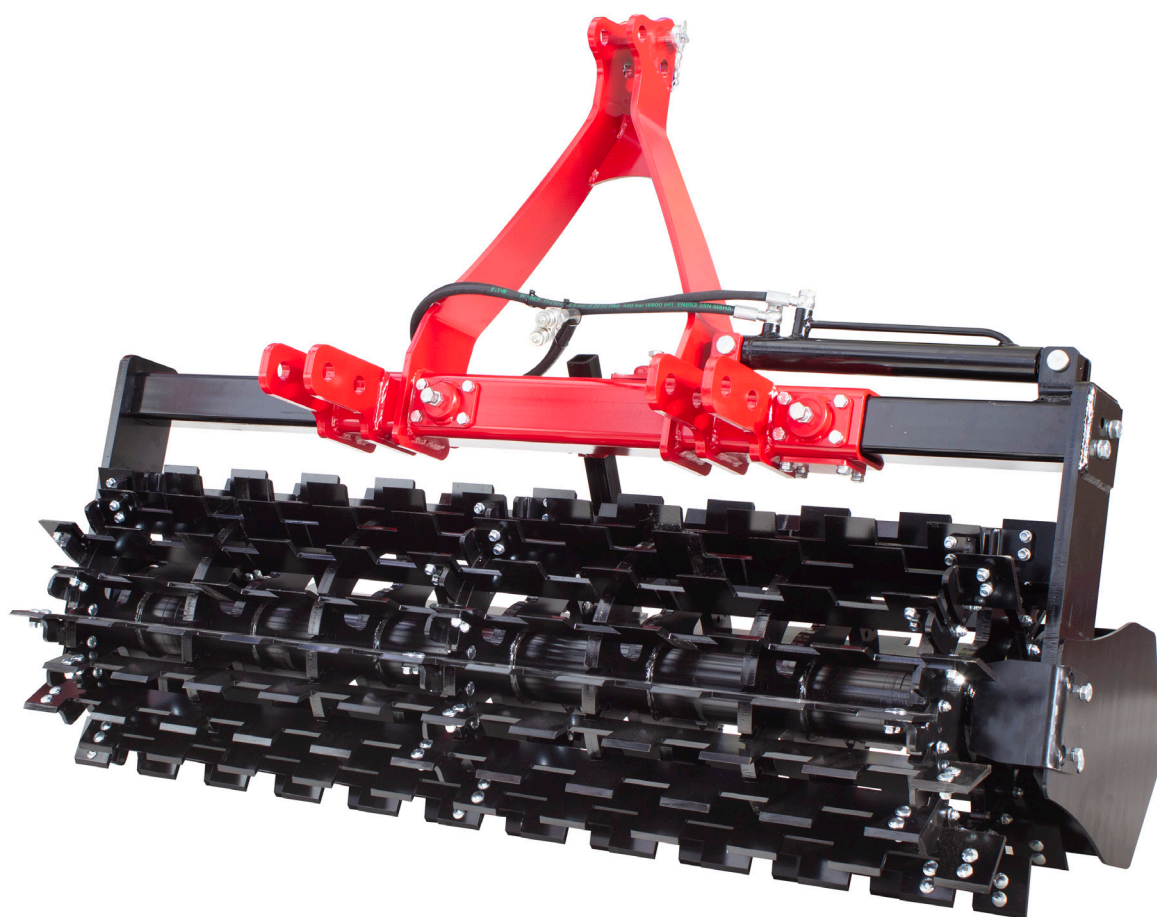

SERIE

# RUNDER



**Reversible mulching roller.** Ideal for knock down the stalks by using spades, keeping the cover crop alive and allowing grass grow through producing the next carpet of organic material.

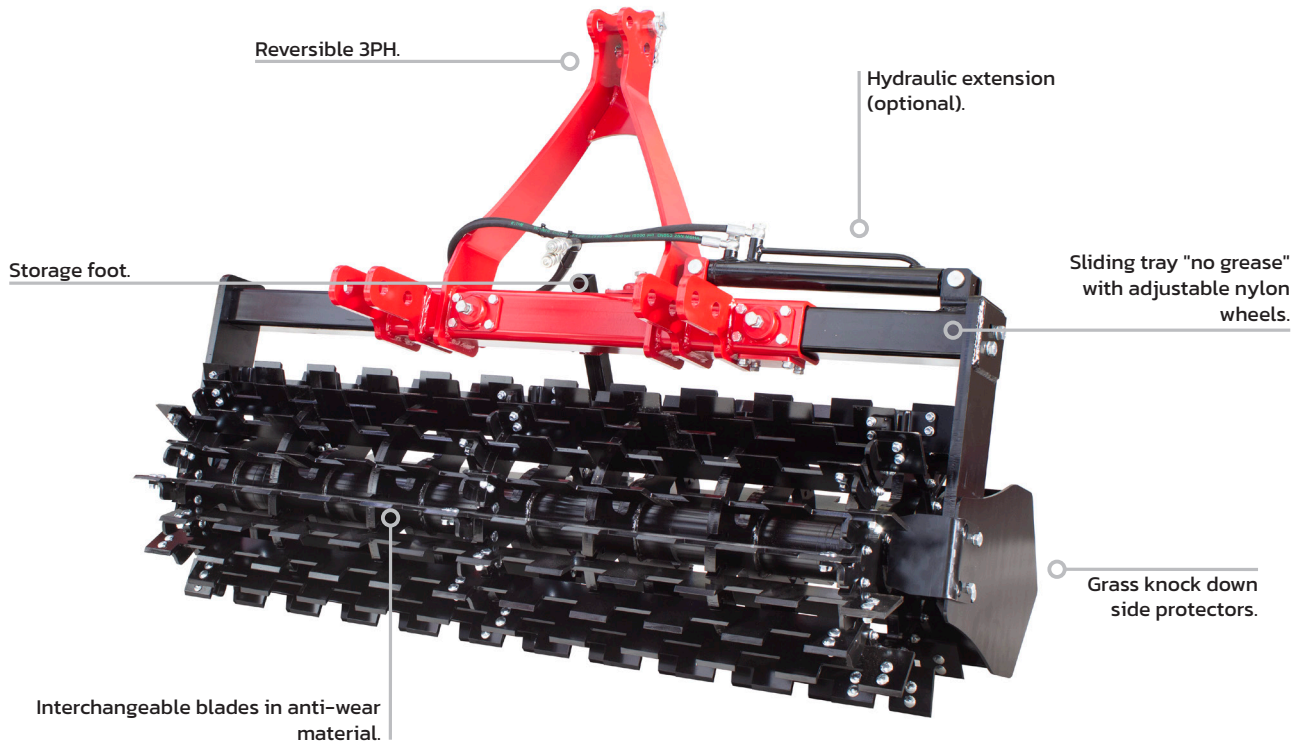

PICTURE MODEL:  
BER-M + CD

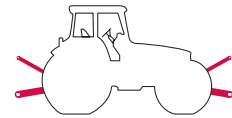

## Versatility

- Models adjustable to any kind of plantation system.
- Possibility of combined work with other implements.
- Perfect work in all type of cover crops.

## Exclusivity

- Possibility of replacing the spades with spike blades to improve oxygenation and water infiltration.
- Interchangeable blades.

## Effectiveness

- Working speeds up to 20 km/h.
- Sustainable consumption: Equipment designed to be up-to-date and have a long service life.

## Reliability

- Heavy duty frame and robotic welding.
- Components and materials of high quality from certified manufacturers.
- Interchangeable blades in anti-wear material.

## Safety

- All models are designed for a safe, simple and intuitive use.

## Sustainability

- Alternative to grass cutting, it allows the use of tractors with less power and, consequently, the reduction of the carbon footprint.
- Our painting is lead-free and without toxic pigments.



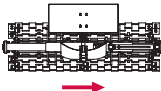
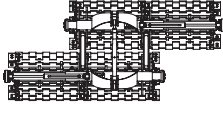

## Standard Equipment

- Reversible chassis for use in front and rear 3rd point.
- Hydraulic extension direct to tractor (HD models).
- Ø500 mm roller equipped with 20 standard interchangeable blades.
- CAT 2 tractor hitch.
- Storage foot.
- Anti-shock protectors on the bearings.

<b>RUNDER</b>		REF.
	m	
	1,50	BER-S
	1,75	BER-M
	2,00	BER-L
<b>HD</b>	1,50-2,00	BER-HD-S
	1,75-2,40	BER-HD-M
	2,00-2,80	BER-HD-L
	2,15-3,15	BER-HD-XL

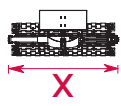

## Technical details

						L	W	H
	REF.	m	m	kg	HP	m	m	m
<b>RUNDER</b>	BER-S	1,50	750-980	430	50	1,60	0,70	1,20
	BER-M	1,75	875-1195	500	50	1,85	0,70	1,20
	BER-L	2,00	1000-1415	560	50	2,10	0,70	1,20
<b>RUNDER HD</b>	BER-HD-S	1,50-2,00	980-980	860	80	1,60	1,10	1,20
	BER-HD-M	1,75-2,40	1195-1195	1000	80	1,85	1,10	1,20
	BER-HD-L	2,00-2,80	1415-1415	1120	80	2,10	1,10	1,20
	BER-HD-XL	2,15-3,15	1575-1575	1120	80	2,25	1,10	1,20

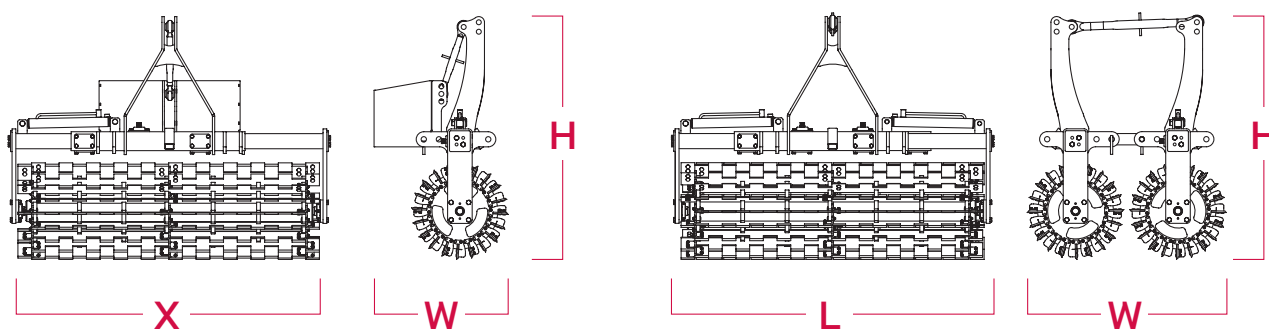

## Tractor mounting



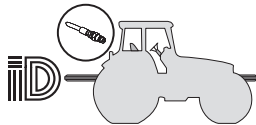
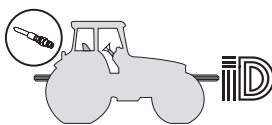
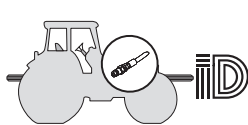

## Tractor connection and assembling

		
<b>STANDARD</b>	REF. CMT-10	REF. CMT-5

## Chassis

### Accessories and Options

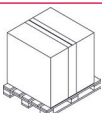
☺	DESCRIPTION	OBSERVATIONS		REF.	
	Kit Spike blades (20 Units)	BER-S		PP-1	
	Kit Spike blades (20 Units)	BER-M		PP-2	
	Kit Spike blades (20 Units)	BER-L		PP-3	
	Kit Spike blades (40 Units)	BER-HD-S		PP-4	
	Kit Spike blades (40 Units)	BER-HD-M		PP-5	
	Kit Spike blades (40 Units)	BER-HD-L / XL		PP-6	
	shifting cylinder	Available for BER-S / M / L models	Directly to the tractor		CD
	Counterweight box	Available for BER-S / M / L models			CP
	Packaging	Basic			EMB-1
		Airfreight- oceanfreight			EMB-2



## Strategic alliancesm, our key to competitiveness

Consolidating knowledge and innovation as driver of our smart growth. We rely on strategic collaboration with universities, polytechnics, research centers, clusters, business associations and experts who enrich our knowledge and our ecosystem.



**INDUSTRIAS DAVID S.L.U.**  
C/ Médico Miguel Lucas s/n  
CP: 30510, Yecla, Murcia-Spain  
Tel.: +34 968 718 119  
[info@id-david.com](mailto:info@id-david.com)

**Connect with us.**  
[instagram.com/iddavid\\_official](https://www.instagram.com/iddavid_official)  
[twitter.com/IDdavidslu](https://twitter.com/IDdavidslu)  
[facebook.com/industriasdavid](https://www.facebook.com/industriasdavid)  
[linkedin.com/company/id-david](https://www.linkedin.com/company/id-david)  
[youtube.com/industriasdavid](https://www.youtube.com/industriasdavid)

[www.id-david.com](http://www.id-david.com)

