

FRT

EN

Mounted precision spreader



VITI



SETO



ARBO



HORTI



DAVID
SMART FARMING SOLUTIONS

SERIE FRT



Mounted precision spreader from 600L to 1000L. Suitable spreading on surface or underground of chemical, granulated, powdery and pellets fertilisers.

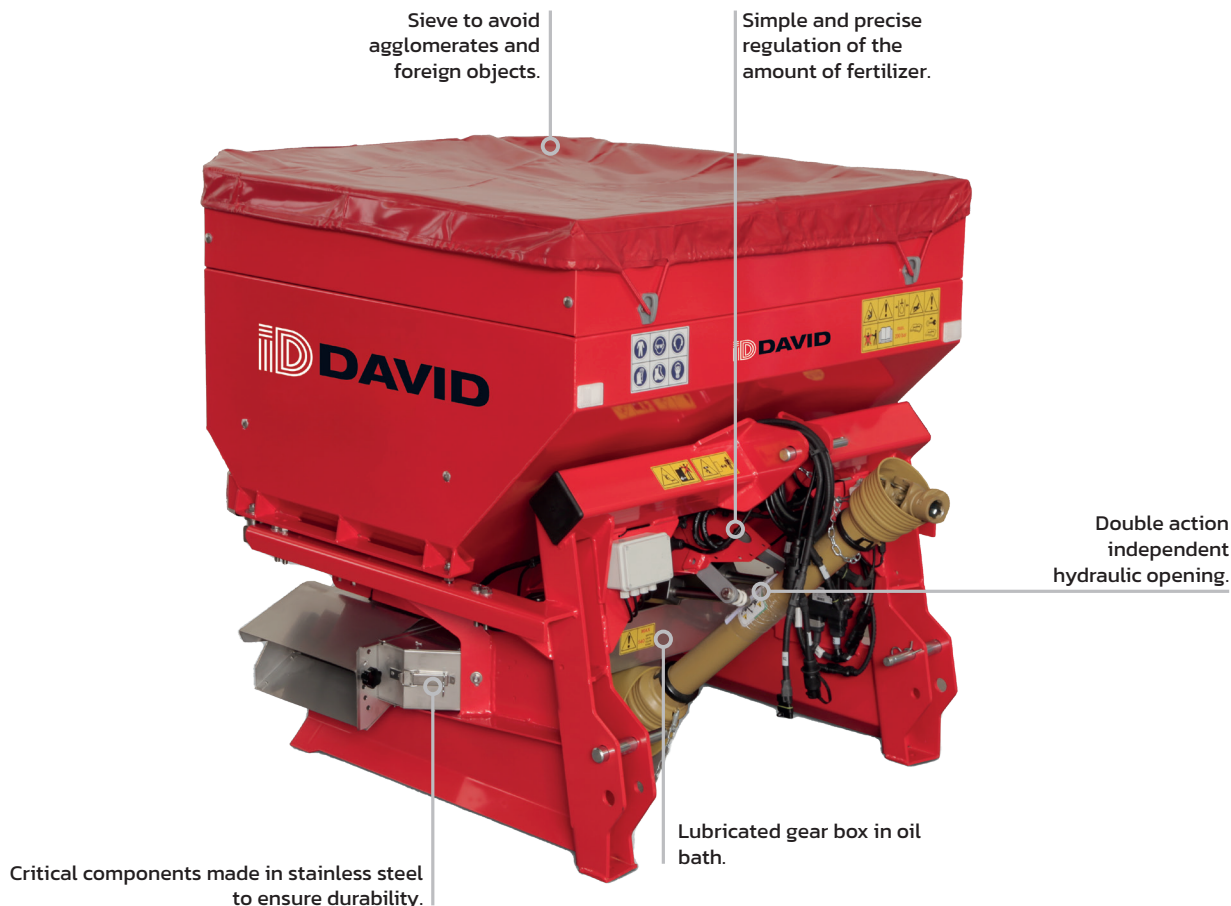

PICTURE MODEL:
FRT-80-E + LCVP-01

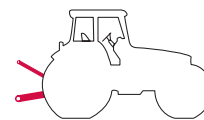
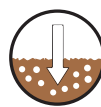

Versatility

- Simple and versatile equipment for fertilization in vineyards, orchards and open fields.
- Suitable for the distribution of granulated fertilizers and pellets.

Reliability

- The plates, vanes, agitators, carter and the discs are made of stainless steel to guarantee its resistance and durability.
- Stainless steel outlets easily removable for cleaning and maintenance.
- Double hydraulic opening by a double acting cylinder.

Exclusivity

- A machine for 3 types of application: surfacely, localizely and subsoiling.

Safety

- The regulation of the opening of the hopper is composed of two independent indicators placed on a graduated scale, simple and visible.
- The discs and spreader vanes are adjustable with high accuracy.

Effectiveness

- Time is valuable, it is possible to work up to 20 km/h with standard soil conditions by equipping electronic dosing system.
- Performance up to 260 kg/min.
- Speed of the discs up to 720 rpm.
- Its exclusive design allows to reach working widths from 1.6 to 18 m.

Sustainability

- The electronic dosing system maintains constant application rate at different speed to optimize fertilizer quantity.
- Controlled release fertilizers can be used thanks to the adjustable double subsoiler, an effective solution for sustainable agriculture.

Standard Equipment

- 3-Point hitch Cat. I and II.
- Polyester powder coating.
- Spreader plates, paddles, agitators and opening discs in stainless steel.
- Boards for the regulation of the spreader according to the type of fertilizer and the kg/ha.
- Sieve to avoid conglomerations and foreign objects.
- Double removable dispenser.
- PTO with safety pin.

Remote control type

MANUAL

- Dosage manual adjusting.
- Hydraulic cylinders for opening and closing the guillotine gate.
- Dosage table to adjust Kg / Ha of different fertilizers.



ELECTRONIC







- Calibration monitor.
- Sensor and cable adaptables on tractor wheel (speed control).
- ISO 11786 cable with 7-pin plug.
- Self-calibration system using 4 precision scales
- Automatic dosing system of Kg / Ha according to the tractor speed.
- Support for electronic monitor with suction cup.



ISOBUS

- ISO 11783 cable (ISOBUS tractor connector or self-guided system).
- Self-calibration system through 4 load cells.
- Automatic dosing system Kg/ha through tractor speed (DPAE).









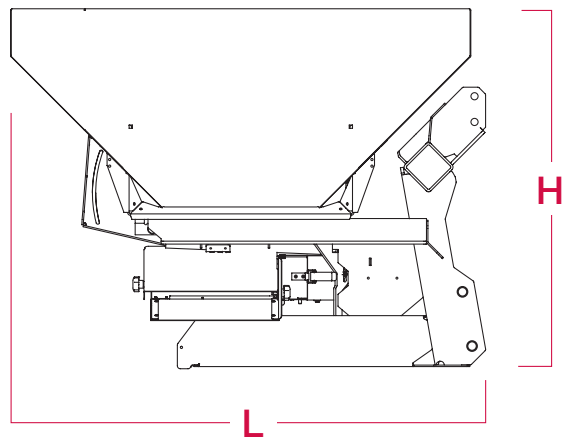
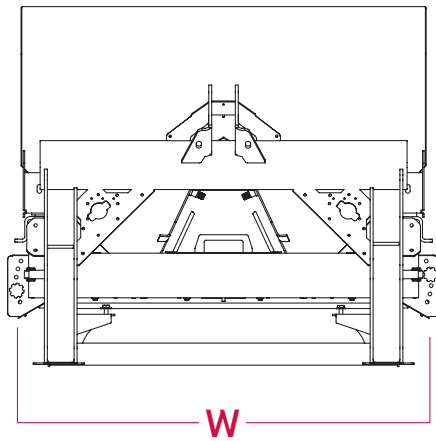

				
FRT	Liters	m	m	REF.
MOUNTED MANUAL 	600	2-6	10-18	FRT-60-M
	800	2-6	10-18	FRT-80-M
	1000	2-6	10-18	FRT-100-M
MOUNTED ELECTRONIC 	600	2-6	10-18	FRT-60-E
	800	2-6	10-18	FRT-80-E
	1000	2-6	10-18	FRT-100-E
MOUNTED WITH ISOBUS 	600	2-6	10-18	FRT-60-I
	800	2-6	10-18	FRT-80-I
	1000	2-6	10-18	FRT-100-I

Technical details

FRT	REF.			L	W	H
		kg	HP	m	m	m
600 LITERS	FRT-60	250	40	1,32	1,20	1,20
800 LITERS	FRT-80	255	50	1,32	1,20	1,40
1000 LITERS	FRT-100	260	60	1,32	1,20	1,60

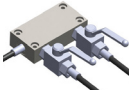

Fertilizer Accessories and Options

	DESCRIPTION	OBSERVATIONS	REF.	
	Subsoiler Kit	Subsoiler kit with adjustable width from 1.6 to 2.2 m	KSC-01	
	PVC cover		LCVP-01	
	LED lights kit		KLL-01	
	Two way unit	 For tractors with a single double acting hydraulic control	UDV-01	
	Extra hopper kit	Increase capacity of 200L (up to 2 units per machine)	AL-200	
	Double sonar for automatic plant detection	Adaptable on the manual model, includes ID BASIC electric box in cabin	Independent Right and left	DSDAP-01
	Cover furrows		Pair	TS-SUB-P

Our commitments

Respect and honesty are fundamental rules of ID David when dealing with customers, employees, suppliers and our planet. The company currently develops and promotes corporate social responsibility.



INDUSTRIAS DAVID S.L.U.
C/ Médico Miguel Lucas s/n
CP: 30510, Yecla, Murcia-Spain
Tel.: +34 968 718 119
info@id-david.com

Connect with us.
[instagram.com/iddavid_official](https://www.instagram.com/iddavid_official)
twitter.com/IDdavidslu
[facebook.com/industriasdavid](https://www.facebook.com/industriasdavid)
[linkedin.com/company/id-david](https://www.linkedin.com/company/id-david)
[youtube.com/industriasdavid](https://www.youtube.com/industriasdavid)

www.id-david.com

