

DEF

EN

Trailer for mineral fertilizer



VITI



SETO



ARBO



HORTI



DAVID
SMART FARMING SOLUTIONS

SERIE

DEF



Trailer for mineral fertilizer. Spreader for mineral fertilizer of 2.5 or 5 m³. Suitable for a surface or localized underground distribution of pellets and granulated.

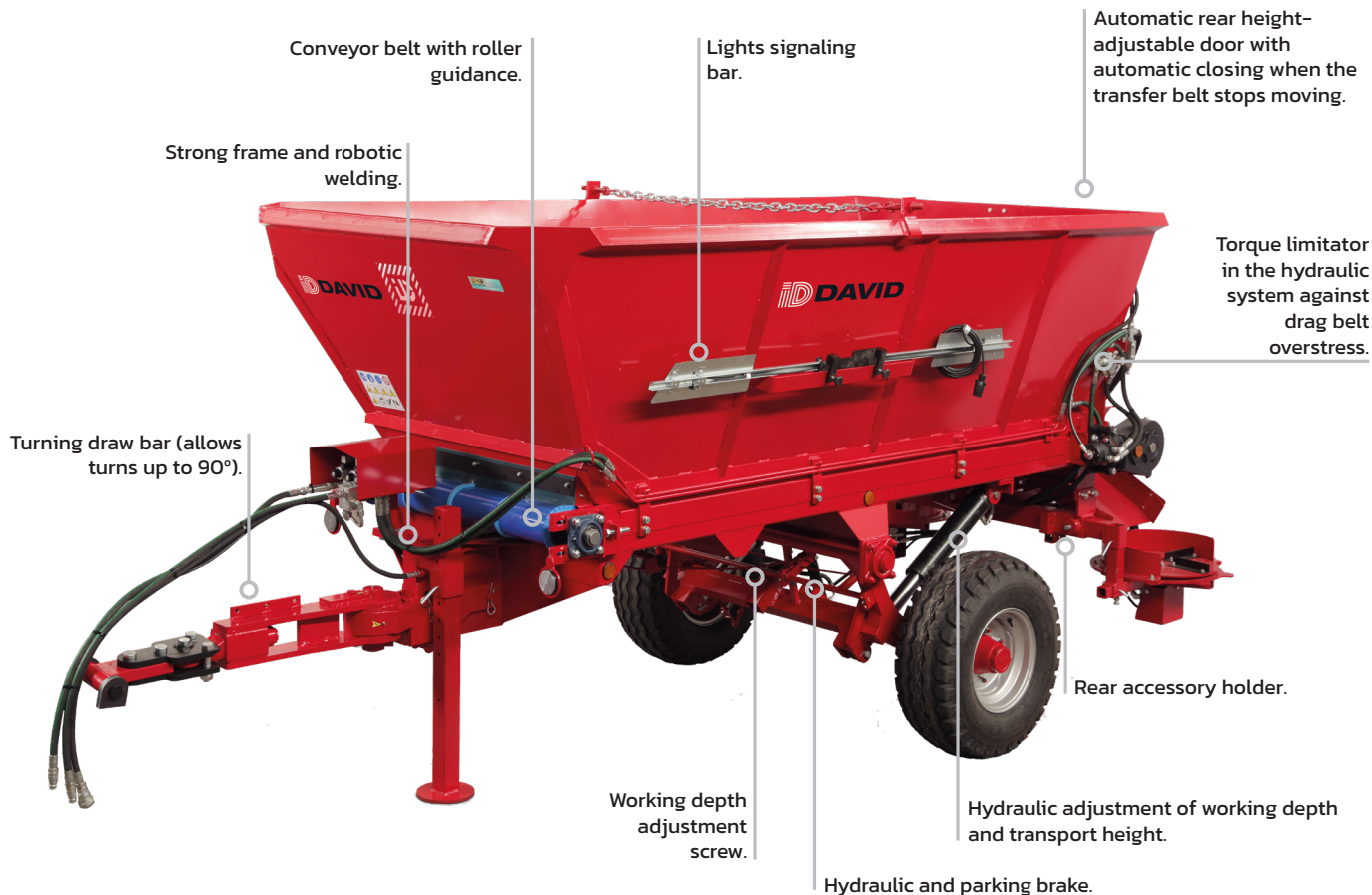

PICTURE MODEL:
DEF-4525-E + DSD-F

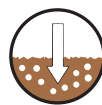

Versatility

- Simple and versatile equipment for fertilization in vineyards, orchards and open fields.
- The widest range of equipment in the market for compost or inorganic fertilizers spreading onto vineyard, fruit trees and open fields.
- Different accessories that allow to distribute the fertilizer according to the crops needs.

Exclusivity

- The first and unique fertilizer spreader with 'automatic coupling system' (Option) to connect and disconnect the machine from the tractor cab in 4 seconds.
- A configuration tailored to customer' needs.

Effectiveness

- Low-power absorption and great maneuverability thanks to the elimination of PTO shaft.
- Constant and uniform dispensing independent from RPM or tractor's speed.
- It works in a magnificent way with any kind of granulated and pellet fertilisers.

Reliability

- Components and materials of high quality.
- Low maintenance requested (no lubrication needed into essential parts).
- Manufacturing experience since 1973.

Safety

- All models are designed for simple and intuitives operations.
- Triple track conveyor belt.
- Fully hydraulic operation in all its functions.

Sustainability

- Controlled release fertilizers and pellets can be used thanks to the adjustable double subsoiler, an effective solution for sustainable agriculture.

Standard Equipment

- Parking brake.
- Hydraulic service brake (Not available in 2.5 m3).
- Working depth adjusting pin.
- Hydraulic adjustment of working depth and transport height.
- Torque limitation security valve on the driving belt.
- Hydraulic driving belt speed regulator (normal and inverted gear).
- Lights signaling bar.
- Rear door (automatic opening and closing).
- 4-ply conveyor belt with triple guide.
- Standing support foot adjustable in height.
- Turning draw bar (allows turn up to 90°).

Remote control type

DIRECT TO TRACTOR











- Hydraulic connection to the tractor by 4 hoses.
- The hydraulic functions are carried out by the tractor distributor.
- ! Electrical connection is NOT required.
- Conveyor speed regulator on the machine.

ELECTRIC CABIN

- Electric control box located in the tractor cabin.
- Hydraulic connection to the tractor by 2 hoses.
- Conveyor speed regulator on the machine.



ERI: AUTOMATIC COUPLING SYSTEM

- Automatic quick hitch with electric control box located in the tractor cab.
- Hydraulic connection to the tractor by 3 hoses.
- Trailer drawbar with quick coupling system. Includes electric and hydraulic quick couplings with flat face (anti-pollution).
- Tractor coupling with tilting system (allows hitching on a slope) and automatic locking system.
- Hydraulic and automatic axle synchronized with the coupling locking system.
- Conveyor speed regulator from the cab.

			DIRECT TO TRACTOR    X4	ELECTRIC CABIN   X2	ERI  +   X3
DEF	m ³	m	REF.	REF.	REF.
TRAILER FOR MINERAL FERTILIZER	2,5	1,5	DEF-4525-T	DEF-4525-E	DEF-4525-ERI
	5	2	DEF-8050-T	DEF-8050-E	DEF-8050-ERI



Technical details



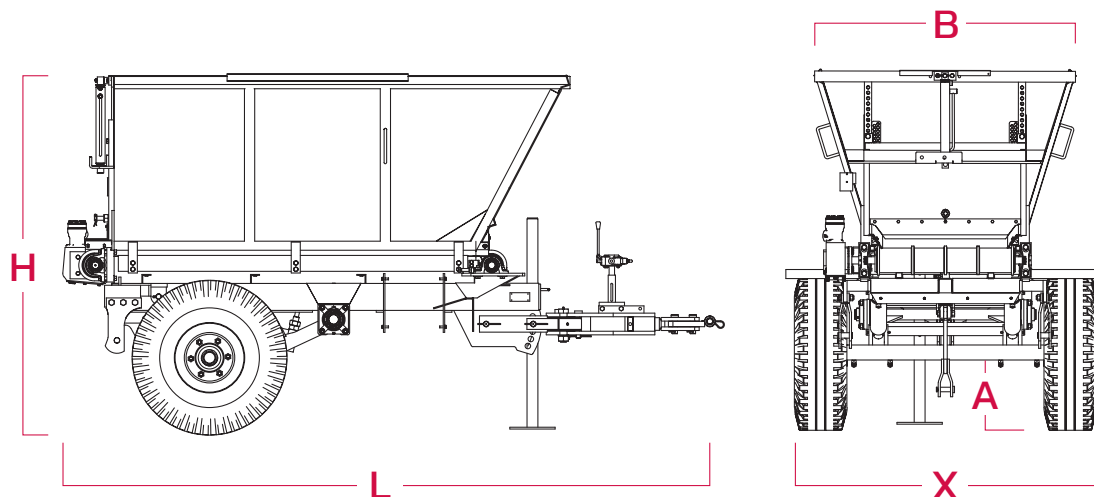





DEF	REF.	X	A	B				L	H
		m	m	m	kg	HP		m	m
TRAILER FOR MINERAL FERTILIZER	DEF-4525	1,50	0,40	1,45	1175	45	7,50 x 16" - Ø805	3,41	2,00-2,60
	DEF-8050	2,00	0,43	1,80	1950	80	11,5/80X15,3" - Ø855	4,62	2,00-2,65



Trailer Accessories and Options

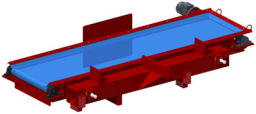
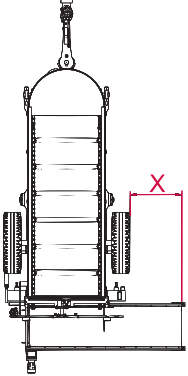

	DESCRIPTION	OBSERVATIONS	REF.
	Standard Vertical Parking support direct to tractor	Up to 6m3  +2 Without E.R.I	MVH-01
	stainless steel hopper sides	Increase by % the price of the model	TPINOX
	Sieve with holes Ø20 mm	With support on hopper	CRB-20
	Assembly plate to the rear of the tractor	Include the form 3 completed For articulated drawbar	PA-T
	Proportional solenoid valve kit, electronic revolution counter and potentiometer	Available for equipment with electric control on cabin	K-EPCR
	Camera + colour screen 7"	For cab rear view	C-TFT
	Hydraulic power unit 60 L for D.E.	Machines without E.R.I.	C6
	Sonar	Available only for electrically controlled machines	SON
	Additional dispenser for microgranules application	Capacity: 200 liters	DSAM20

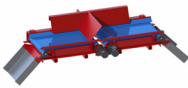
Accessories to use on surface

	DESCRIPTION	OBSERVATIONS	REF.	
	Double disc spreader with ramp for vineyard	Special for mineral fertilizers or pellets	DSD	
	Double spreading disc with vibrating ramp Model HD orchard	Special for mineral fertilizers or pellets	DSD-F	
	Free fall ramp	To create surface layer	RCL	
 	Side unloading belt and hydraulic extension	 Directly to the tractor	CSL501	
		Short (x = 50 cm max)	Electric cabine	CSL503
			Quick coupling (E.R.I.)	CSL504
			 Directly to the tractor	CSL751
		Medium (x = 75 cm max)	Electric cabine	CSL753
			Quick coupling (E.R.I.)	CSL754
			 Directly to the tractor	CSL101
		Long (x = 100 cm max)	Electric cabine	CSL103
			Quick coupling (E.R.I.)	CSL104
	Ø700 disc for coupling to the side unloading belt		DDL700	
	Double lateral belt two falls	Small (from 1.65 to 2.65m)	CDLC-S	
		Medium (1.95 to 2.95 m)	CDLC-M	
		Large (From 2,40 to 3,40 m)	CDLC-L	

*It becomes triple fall dismantling the central ramp

Accessories to use on subsoil

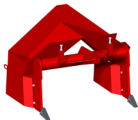
	DESCRIPTION	OBSERVATIONS	REF.
	Subsoiler frame with 4 outlets + 2 hydraulic markers		CSA
	Simple subsoiler		SSC-F
	Double subsoiler	Normal fix	Distance between elements 1200 mm DS12-F
			Distance between elements 1400 mm DS14-F
		Adjustable width	Distance between elements 1200 to 1600 mm DS1216-R



DESCRIPTION

OBSERVATIONS

REF.

Right subsoiler with lateral unloading band and hydraulic extension



Directly to the tractor

DSL501F

Short
(x = 50 cm max)

Electric cabine

DSL503F

Quick coupling
(E.R.I.)

DSL504F



Directly to the tractor

DSL751F

Medium
(x = 75 cm max)

Electric cabine

DSL753F

Quick coupling
(E.R.I.)

DSL754F



Directly to the tractor

DSL101F

Long
(x = 100 cm max)

Electric cabine

DSL103F

Quick coupling
(E.R.I.)

DSL104F

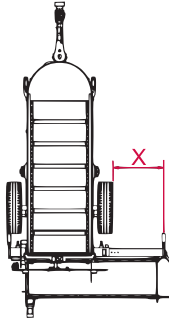
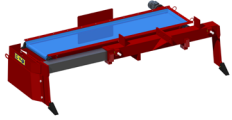

Narrow
Distance between elements
1400 to 1800 mm

Manual Extension

DSC-C14

Hydraulic width adjusting

DSC-C14H

Large
Distance between element
1600 to 2000 mm

Manual Extension

DSC-C160

Hydraulic width adjusting

DSC-C16H

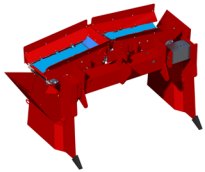

Doble subsoiler with belt

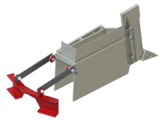

Cover furrows

Unit

TS-SUB-F

Our commitments

Respect and honesty are fundamental rules of ID David when dealing with customers, employees, suppliers and our planet. The company currently develops and promotes corporate social responsibility.



INDUSTRIAS DAVID S.L.U.
C/ Médico Miguel Lucas s/n
CP: 30510, Yecla, Murcia-Spain
Tel.: +34 968 718 119
info@id-david.com

Connect with us.
[instagram.com/iddavid_official](https://www.instagram.com/iddavid_official)
twitter.com/IDdavidslu
[facebook.com/industriasdavid](https://www.facebook.com/industriasdavid)
[linkedin.com/company/id-david](https://www.linkedin.com/company/id-david)
[youtube.com/industriasdavid](https://www.youtube.com/industriasdavid)

www.id-david.com

