

# DEA

EN

*Over-the-row spreader for manure application*



# SERIE DEA



**Over-the-row spreader for manure application.** Its high axle between the wheels allows to work on crops up to 87 cm high, such as V shape vineyards, sugar cane and all crops using a over-the-row tractor.

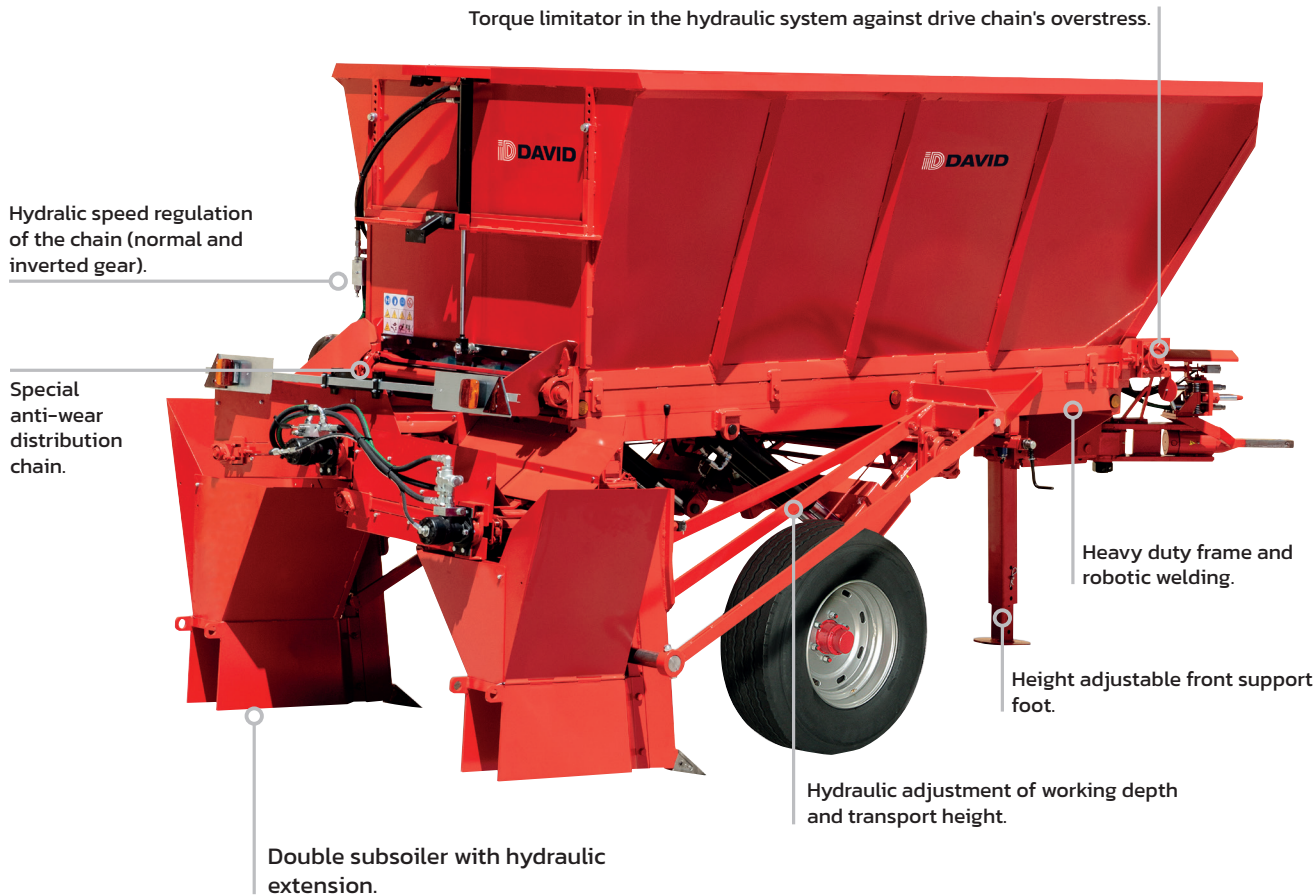

PICTURE MODEL:  
DEA-9060-ERI

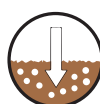

## Versatility

- Simple and versatile equipment for fertilization in V shape vineyards, sugar cane or vegetables.
- The widest range of equipment in the market for compost or inorganic fertilizers spreading onto vineyard, fruit trees and open fields.
- Different accessories that allow to distribute the fertilizer according to the crops needs.

## Exclusivity

- The first and unique fertilizer spreader with 'automatic coupling system' (Option) to connect and disconnect the machine from the tractor cab in 4 seconds.
- A configuration tailored to customer' needs.
- Its special high shape allows to work over the crops.

## Effectiveness

- Low-power absorption and great maneuverability thanks to its articulated drawbar and the elimination of PTO Shaft.
- Constant and uniform dispensing independent from RPM or tractor's speed.
- Magnificent work with any type of organic fertilizer. Magnificent crumbled and excellent cast.
- Roller chain and special anti-wear steel for professional use to get high performances.

## Reliability

- Components and materials of high quality.
- Low maintenance (no lubrication in its essential parts).
- Manufacturing experience since 1973.

## Safety

- All models are designed for simple and intuitives operations.
- Fully hydraulic operation in all its functions.

## Sustainability

- The most consistent and sustainable option in the medium-long term for organic farming is the enhancement of soil properties and the use of composted fertilizers. These are the richest in carbon, slow release and humus precursors.
- Increase the organic matter level and, consequently, the biological activity means improving soil production capacity and resiliency.

## Standard Equipment

- Parking brake.
- Hydraulic service brake.
- Working depth adjusting pin.
- Hydraulic driving belt speed regulator (normal and inverted gear).
- Torque limitation security valve on the driving belt.
- Hydraulic adjustment of working depth and transport height.
- Lights signaling bar.
- Rear door (automatic opening and closing).
- Drive chain in anti-wear steel.
- Double hydraulic extensible chains subsoiler (DSZ16H).
- Standing support foot adjustable in height.
- Turning draw bar (allows turns up to 90°).

## Remote control type

### DIRECT TO TRACTOR









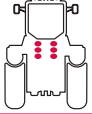

- Hydraulic connection to the tractor by 4 hoses.
- The hydraulic functions are carried out by the tractor distributor.
- ! Electrical connection is NOT required.
- Equipment traction chain speed regulator.

### ELECTRIC CABIN

- Electric control box located in the tractor cabin.
- Hydraulic connection to the tractor by 2 hoses.
- Equipment traction chain speed regulator.



### ERI: AUTOMATIC COUPLING SYSTEM

- Automatic quick hitch with electric control box located in the tractor cab.
- Hydraulic connection to the tractor by 3 hoses.
- Trailer drawbar with quick coupling system. Includes electric and hydraulic quick couplings with flat face (anti-pollution).
- Tractor coupling with tilting system (allows hitching on a slope) and automatic locking system.
- Hydraulic and automatic axle synchronized with the coupling locking system.
- Unloading chain speed regulator from the cab.

			<b>DIRECT TO TRACTOR</b>    X4	<b>ELECTRIC CABIN</b>   X2	<b>ERI</b>  +   X3
<b>DEA</b>	m <sup>3</sup>	m	REF.	REF.	REF.
<b>TRAILED FERTILIZER WITH DOUBLE RIPPER</b>	<b>4</b>	<b>1,94</b>	DEA-7540-T	DEA-7540-E	DEA-7540-ERI
	<b>6</b>	<b>2,18</b>	DEA-9060-T	DEA-9060-E	DEA-9060-ERI
	<b>8</b>	<b>2,34</b>	DEA-10080-T	DEA-10080-E	DEA-10080-ERI
	<b>10</b>	<b>2,34</b>	DEA-125100-T	DEA-125100-E	DEA-125100-ERI
	<b>13</b>	<b>2,40</b>	DEA-150130-T	DEA-150130-E	DEA-150130-ERI







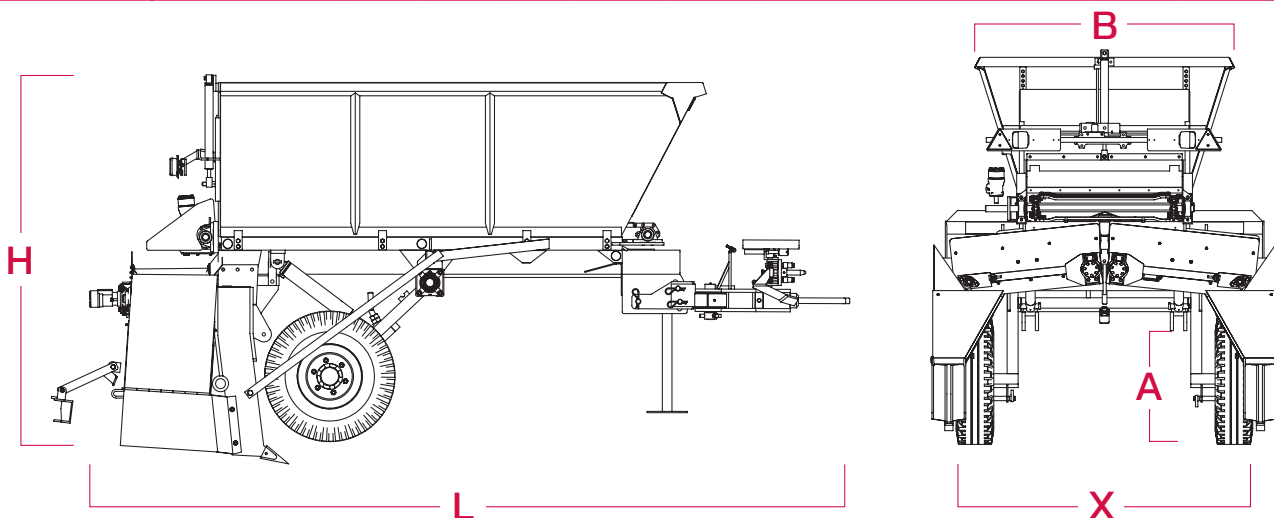



## Technical details





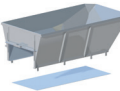

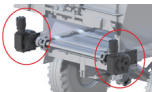
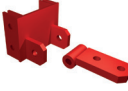
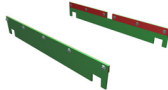
DEA	REF.	X	A	B				L	H
		m	m	m	kg	HP		m	m
<b>TRAILED FERTILIZER WITH DOUBLE RIPPER</b>	DEA-7540	1,94	0,76	1,65	2550	75	11,5/80X15,3" - Ø855	5,25	1,90-2,70
	DEA-9060	2,18	0,76	1,95	3150	95	13,0/65X18" - Ø908	5,37	2,54-3,15
	DEA-10080	2,34	0,80	1,95	3400	100	385/65R-22,5" - Ø1072	5,75	2,57-3,20
	DEA-125100	2,34	0,82	1,95	3550	125	385/65R-22,5" - Ø1072	6,25	2,50-3,20
	DEA-150130	2,40	0,87	2,15	4500	150	445/65R-22,5" - Ø1150	7,59	2,79-3,50





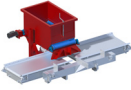

## Trailer

### Accessories and Options





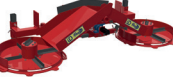

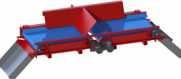

	DESCRIPTION	OBSERVATIONS	REF.
	Standard Vertical Parking support direct to tractor	Up to 6m3 	Without E.R.I MVH-01
	Reinforced vertical parking support direct to tractor	Starting from 8 m3 	Without E.R.I MVH-03
	stainless steel hopper sides	Increase by % the price of the model	TPINOX
	Manure anti-compaction kit		KATC-01
	Wide automatic gate	Starting from machines 6 m3	Not available with round hopper CA-A
	Double trailed motor kit	For 8 m3 machines	Included on 10 and 13m3 DMA
	Assembly plate to the rear of the tractor	Include the form 3 completed	PA-T
	Rubber mudguards kit	use with sewage sludge, lime and pellet	KFG-LD
	Pair of chain lubrication tanks		2BEC

	DESCRIPTION	OBSERVATIONS	REF.
	Camera + colour screen 7"	For cab rear view	C-TFT
	Hydraulic power unit 60 L for D.E.	Machines without E.R.I.	C6
	Sonar	Available only for electrically controlled machines	SON
	Additional dispenser for microgranules application	Capacity: 200 liters	DSAM20
	Price addition for chain to be used with pellets and lime	Distance between transoms 115 mm	ICP-05
		Distance between transoms 230 mm	4-6 m <sup>3</sup> ICP-06
		Distance between transoms 230 mm	8 m <sup>3</sup> ICP-07
		Distance between transoms 230 mm	10 m <sup>3</sup> ICP-08
		Distance between transoms 230 mm	13 m <sup>3</sup> ICP-09
*Greater number of transoms			

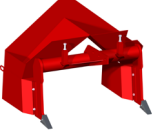
## Accessories to use on surface

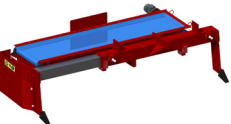
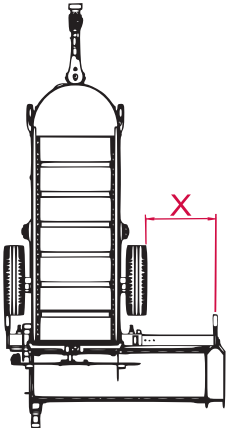
	DESCRIPTION	OBSERVATIONS	REF.
	Spreading disc without shaft	Machines 4 m <sup>3</sup>	Ø1100 mm DE1-110
		Machines from 6 to 8 m <sup>3</sup>	Ø1250 mm DE1-125
		Machines starting from 10 m <sup>3</sup>	Ø1500 mm DE1-150
	Double disc spreader with ramp for vineyard	Special for mineral fertilizers or pellets	DSD
	Double spreading disc with vibrating ramp Model HD orchard	Special for mineral fertilizers or pellets	DSD-F
	Free fall ramp	To create surface layer	RCL
	Disc adaptable to side unloading belt	Ø700 mm	DDL700
	Double lateral belt two falls	Small (from 1.65 to 2.65m)	CDLC-S
		Medium (1.95 to 2.95 m)	CDLC-M
		Large (From 2,40 to 3,40 m)	CDLC-L
*It becomes triple fall dismounting the central ramp			

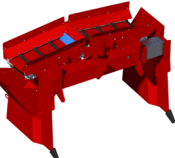
## Accessories to use on subsoil

	DESCRIPTION	OBSERVATIONS	REF.
	Simple central subsoiler		SSC-A
		Distance between elements 1200 mm	DSZ120
	Double ripper subsoiler	Normal fix	
		Distance between elements 1400 mm	DSZ140
		Vibrator and adjustable width	
		Distance between elements 1200 to 1600 mm	DSZ-V
	Right subsoiler with lateral unloading band	 +2	DSL501Z
	Short (x = 50 cm max)	Electric cabine	DSL503Z
		Quick coupling (E.R.I.)	DSL504Z
		 +2	DSL751Z
	Medium (x = 75 cm max)	Electric cabine	DSL753Z
		Quick coupling (E.R.I.)	DSL754Z
	Long (x = 100 cm max)	 +2	DSL101Z
		Electric cabine	DSL103Z
		Quick coupling (E.R.I.)	DSL104Z
	Double long-legged schank subsoiler with chains	Large Distance between element 1600 to 2300 mm	Hydraulic width adjusting *Included as standard
	Cover furrows	Unit	TS-SUB

## Our commitments

Respect and honesty are fundamental rules of ID David when dealing with customers, employees, suppliers and our planet. The company currently develops and promotes corporate social responsibility.



**INDUSTRIAS DAVID S.L.U.**  
C/ Médico Miguel Lucas s/n  
CP: 30510, Yecla, Murcia-Spain  
Tel.: +34 968 718 119  
[info@id-david.com](mailto:info@id-david.com)

**Connect with us.**  
[instagram.com/iddavid\\_official](https://www.instagram.com/iddavid_official)  
[twitter.com/IDdavidslu](https://twitter.com/IDdavidslu)  
[facebook.com/industriasdavid](https://www.facebook.com/industriasdavid)  
[linkedin.com/company/id-david](https://www.linkedin.com/company/id-david)  
[youtube.com/industriasdavid](https://www.youtube.com/industriasdavid)

[www.id-david.com](http://www.id-david.com)

