

PROFEED

EN

Professional spreader for organic solid fertilizers (manure)



SERIE

PROFEED



Professional spreader for organic solid fertilizers (manure). It fits external chains avoiding contact with manure. The machine spread up to 15 m.



PICTURE MODEL:
DESP-130100-ERI



Versatility

- Simple and versatile equipment for fertilization in open fields.
- The widest range of equipment in the market for compost or inorganic fertilizers spreading onto vineyard, fruit trees and open fields.
- Different accessories that allow to distribute the fertilizer according to the crops needs.

Reliability

- Components and materials of high quality.
- Low maintenance (no lubrication in its essential parts).
- Roller chain and special anti-wear steel for professional use to get high performances.
- Manufacturing experience since 1973.

Exclusivity

- The first and unique fertilizer spreader with 'automatic coupling system' (Option) to connect and disconnect the machine from the tractor cab in 4 seconds.
- Modular construction system of the hopper. Allows substitutions of hopper sections in the event of breaks or dents.

Safety

- All models are designed for simple and intuitives operations.
- Fully hydraulic operation in all its functions.

Effectiveness

- Low-power absorption and great maneuverability thanks to the elimination of PTO shaft.
- Constant and uniform dispensing independent from RPM or tractor's speed.
- Magnificent work with any type of organic fertilizer. Magnificent crumbled and excellent cast.

Sustainability

- The most consistent and sustainable option in the medium-long term for organic farming is the enhancement of soil properties and the use of composted fertilizers. These are the richest in carbon, slow release and humus precursors.
- Increase the organic matter level and, consequently, the biological activity means improving soil production capacity and resiliency.

Standard Equipment

- Parking brake.
- Hydraulic service brake.
- Hydraulic driving belt speed regulator (normal and inverted gear).
- Torque limitation security valve on the driving belt.
- Lights signaling bar.
- Exterior super reinforced driving chain made of special anti-wear steel.
- Double piston rear door (automatic opening and closing).
- Spreader disc Ø1500.
- Drawbar with fixed towing and ball ring hitch 65 cm from the ground (for machines without ERI).
- Standing support foot adjustable in height.
- Double motor for drag chain.
- Pair of tanks for chain lubrication.

Remote control type

DIRECT TO TRACTOR









- Hydraulic connection to the tractor by 2 hoses.
- The hydraulic functions are carried out by the tractor distributor.
- ! Electrical connection is NOT required.
- Equipment traction chain speed regulator.

ELECTRIC CABIN

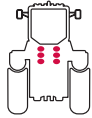
- Electric control box located in the tractor cabin.
- Hydraulic connection to the tractor by 2 hoses.
- Equipment traction chain speed regulator.

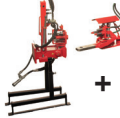

ERI: AUTOMATIC COUPLING SYSTEM

- Automatic quick hitch with electric control box located in the tractor cab.
- Hydraulic connection to the tractor by 3 hoses.
- Trailer drawbar with quick coupling system. Includes electric and hydraulic quick couplings with flat face (anti-pollution).
- Tractor coupling with tilting system (allows hitching on a slope) and automatic locking system.
- Hydraulic and automatic axle synchronized with the coupling locking system.
- Unloading chain speed regulator from the cab.

			 DIRECT TO TRACTOR   X2	 ELECTRIC CABIN  X2	 ERI  +  X3
PROFEED	m ³	m	REF.	REF.	REF.
	8	2,46	DESP-10080-T	DESP-10080-E	DESP-10080-ERI
PROFESIONAL TRAILER	10	2,46	DESP-130100-T	DESP-130100-E	DESP-130100-ERI
	13	2,46	DESP-130130-T	DESP-130130-E	DESP-130130-ERI







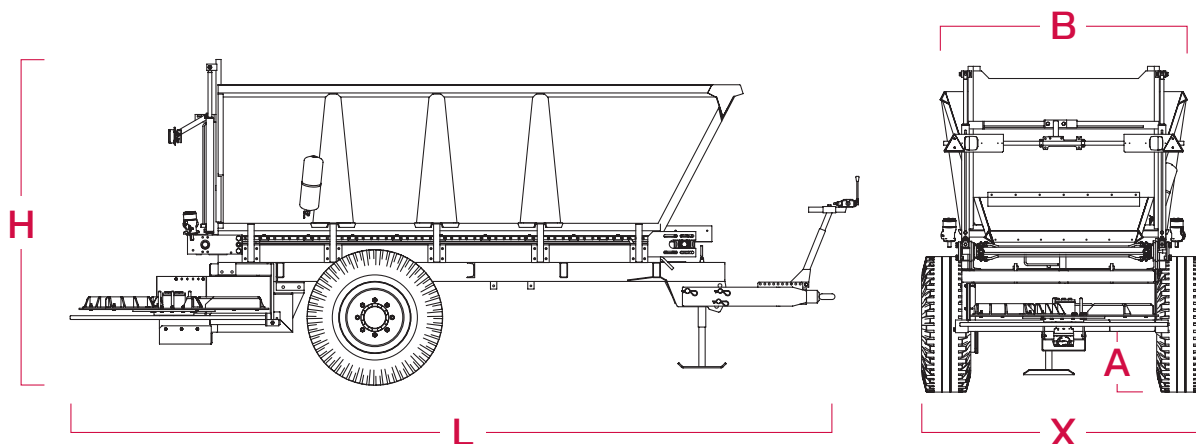

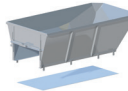

Technical details

PROFEED	REF.	X	A	B				L	H
		m	m	m	kg	HP		m	m
PROFESIONAL TRAILER	DESP-10080	2,46	0,47	1,95	3200	85	445/65R x 22,5" - Ø1150	6,25	2,33
	DESP-130100	2,46	0,47	1,95	4100	100	445/65R x 22,5" - Ø1150	6,80	2,34
	DESP-130130	2,46	0,55	2,15	4875	130	445/65R x 22,5" - Ø1150	8,00	2,68

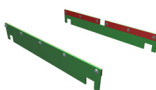

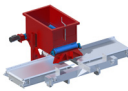
Trailer Accessories and Options

	DESCRIPTION	OBSERVATIONS	REF.	
	Reinforced vertical parking support direct to tractor	Starting from 8 m3  Without E.R.I	MVH-03	
	stainless steel hopper sides	Increase by % the price of the model	TPINOX	
	Manure anti-compaction kit		KATC-01	
	Assembly plate to the rear of the tractor	For machines with ERI Include the form 3 completed	PA-T	
	Rubber mudguards kit	use with sewage sludge, lime and pellet	KFG-LD	
	Camera + colour screen 7"	For cab rear view	C-TFT	
	Hydraulic power unit 60 L for D.E.S.	Machines without E.R.I.	C6	
	Additional dispenser for microgranules application	Capacity: 200 liters	DSAM20	
	Price addition for chain to be used with pellets and lime		8 m3	ICP-07
		Distance between transoms 150 mm	10 m3	ICP-08
			13 m3	ICP-09

*Greater number of transoms

Our commitments

Respect and honesty are fundamental rules of ID David when dealing with customers, employees, suppliers and our planet. The company currently develops and promotes corporate social responsibility.



INDUSTRIAS DAVID S.L.U.
C/ Médico Miguel Lucas s/n
CP: 30510, Yecla, Murcia-Spain
Tel.: +34 968 718 119
info@id-david.com

Connect with us.
[instagram.com/iddavid_official](https://www.instagram.com/iddavid_official)
twitter.com/IDdavidslu
[facebook.com/industriasdavid](https://www.facebook.com/industriasdavid)
[linkedin.com/company/id-david](https://www.linkedin.com/company/id-david)
[youtube.com/industriasdavid](https://www.youtube.com/industriasdavid)

www.id-david.com

