

I-DUST

EN

*High performance and high quality
hydraulic duster*



SERIE

I-DUST



High performance and high quality hydraulic duster. The dosage is homogeneous and precise with all types of powdered or microgranular products thanks to its hydraulic endless screw system. The hopper is stainless and pressurized.



PICTURE MODEL:
ARH-730-L



Versatility

- Possibility of using any powder or microgranular product.
- Homogeneous mixture of different products to be applied simultaneously, avoiding cavitation and allowing product pulverisation.
- Adaptable to any vineyards and orchards.

Reliability

- Easy to calibrate and extremely accurate and reliable.
- The electronic dispenser allows to an easy and accurate adjust of the Kg/ha.
- The hydraulic system protects the equipment from overstress caused by misuse.
- Manufacturing experience since 1975.

Exclusivity

- The sole duster on the market made by stainless steel, pressurized, volumetric and with an hydraulic paddle mixer.
- Simple and precise proportional electronic doser. All the controls in the cabin.
- All the components, having contacts with the sulfur, are made of stainless steel (hopper, endless, mixing area and outlets).

Safety

- The powder has no contact with the turbine, which avoids both problems related to imbalances and fire risks.
- The freewheeling PTO provides a total protection when air generation and to propulsion system.
- A metal grid, installed on the upper part of the hopper, protects people from internal moving elements and prevents the entry of foreign matter.

Effectiveness

- The pressurized hopper and its powerful turbine provide maximum efficiency and working width up to 25 m.
- Working speeds up to 15 km/h.
- The hopper and its large upper gate are designed to be able to load 1 complete big bag in few seconds.
- The depressurization of the hopper is easily detected and allows to know exactly when emptying.

Sustainability

- Perfect solution for crop protection with natural and ecological products such as sulfur.
- The low power required allows the use of small tractors with a lower carbon footprint.
- An effective solution that allows a considerable working time reduction per hectare.

Standard Equipment

- Electronic dosing display.
- Stainless steel turbine of 4.050 r.p.m. Independent of dosification.
- Hydraulic mixing product system.
- Product extraction using augers.
- Sieve to avoid conglomerations and foreign objects.
- Positionable and adjustable stainless steel rear deflectors (outlets).
- Propeller with 2 speed and neutral point.
- Position lights leds.
- Front wheel for easy store.
- Floating wheels.
- P.T.O. with free wheel.
- Drawbar with tilting ball ring.

Functionality

• ELETRONIC DOSING CONTROL FROM THE TRACTOR CAB

The eletronic dispenser allows to an easy and accurate adjust of the Kg/ha.



• HYDRAULIC MIXING

Its hydraulic paddle mixer helps to eliminate lumps, avoiding caves, compaction and allowing the application of product mixtures such as sulfur and copper in a homogeneous and precise way.

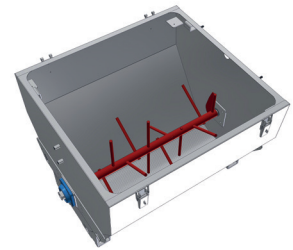

I-DUST			REF.
TRAILED 730 LITERS		25	ARH-730-L
MOUNTED 730 LITERS		25	ARH-730-S





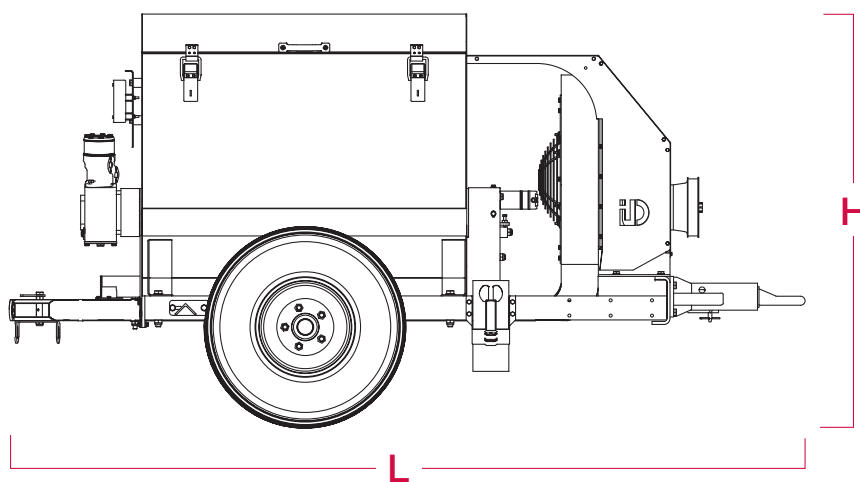
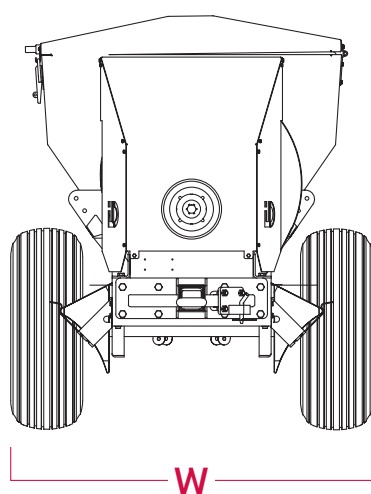

Technical details

				L	W	H
I-DUST	REF.	kg	HP	m	m	m
TRAILED 730 LITERS	ARH-730-L	510	60	2,65	1,20-1,50	1,40
MOUNTED 730 LITERS	ARH-730-S	560	90	2,65	1,20	1,40

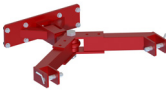

Sulfur duster Accessories and Options

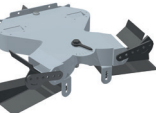
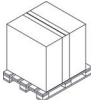
	DESCRIPTION	OBSERVATIONS	REF.
	Drawbar with tilting ball ring	Standard included	ERBA
	Connecting bar to tractor's hitches	Adaptable to drawbar with tilting ball ring eye	BEBT
	V Connection to 3point hitch With homokinetic transmission	Replaces connection and transmission standard	EV3PT
	Homokinetic shaft	Unit	THRL-1
		Replace the standard	THRL-2
	Specials deflectors for pergola vine-growing and orchards	Extra	FP-1
		Replace the standard	FP-2
	Packaging	Basic	EMB-1
		Airfreight- oceanfreight	EMB-3

Do you know...

I-DUST awarded the prestigious EIMA 20/21 International Mention.

New design, possible use with mixed products, innovation and respect for the environment are its mainly characteristics.



INDUSTRIAS DAVID S.L.U.
C/ Médico Miguel Lucas s/n
CP: 30510, Yecla, Murcia-Spain
Tel.: +34 968 718 119
info@id-david.com

Connect with us.
[instagram.com/iddavid_official](https://www.instagram.com/iddavid_official)
twitter.com/IDdavidslu
[facebook.com/industriasdavid](https://www.facebook.com/industriasdavid)
[linkedin.com/company/id-david](https://www.linkedin.com/company/id-david)
[youtube.com/industriasdavid](https://www.youtube.com/industriasdavid)

www.id-david.com

