

PV-L

EN

L-shaped trimmer for vines and hedges



VITI



SETO



DAVID
SMART FARMING SOLUTIONS

SERIE

PV-L



L-shaped trimmer for vines and hedges. Designed to control canopy growth in small farms or hillside plantations. It allows high working speeds, a clean cut, low maintenance and excellent vision from the cab.

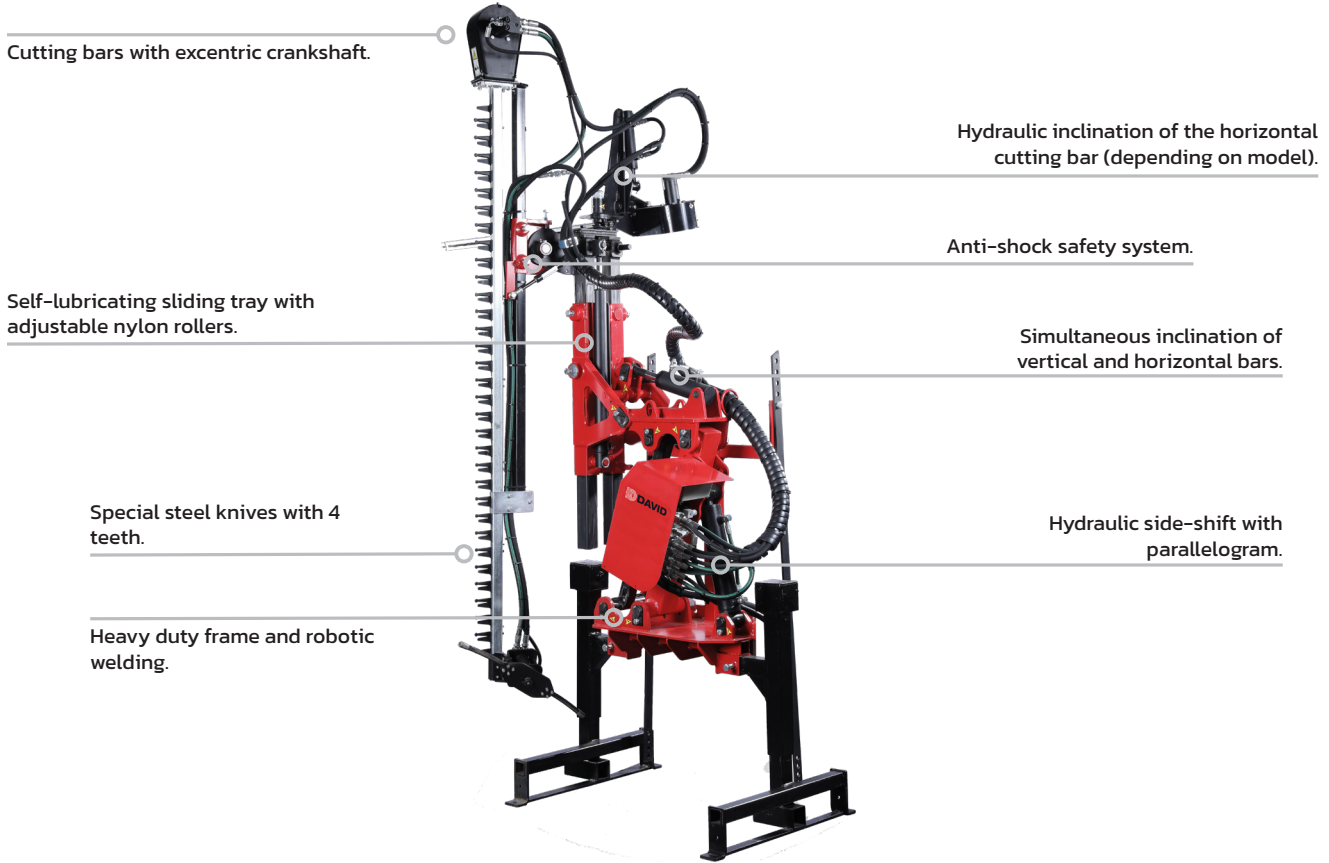

Cutting bars with excentric crankshaft.

Hydraulic inclination of the horizontal cutting bar (depending on model).

Anti-shock safety system.

Self-lubricating sliding tray with adjustable nylon rollers.

Simultaneous inclination of vertical and horizontal bars.

Special steel knives with 4 teeth.

Hydraulic side-shift with parallelogram.

Heavy duty frame and robotic welding.

PICTURE MODEL:
PVL-LA-1710 + LSN-D

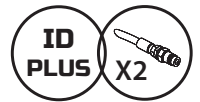
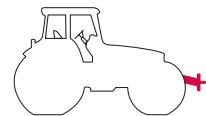

Versatility

- The ID-CONTROL joystick allows to control all the machines manufactured by ID David and equipped with the ID-PLUS or ID-MICRO technology.
- Models adjustable to any kind of plantation system.

Exclusivity

- The crankshaft runs unbalanced moving the blades for a 70% and counter blade for 30% to get a better penetration on the canopy.
- Blades sliding guides made of synthetic material with sliding properties.

Effectiveness

- It allows a working speed up to 12 km/h and a quality cut like "scissors".
- Electrohydraulic system optimized for extremely low power consumption.
- The cut type "scissor" generates less necrosis in certain types of crops compared to the cut by using a disc.

Reliability

- Components and materials of high quality.
- Low maintenance (no needs of lubrication in its key parts).
- Cutting elements supported by years of experience in the market.
- Manufacturing experience since 1975.

Safety

- The strong cutting bars allow green and dry cut.
- Total absence of branches pulled outside compared to the use of rotary knives trimmers.
- Frame with a high vision during work phase.

Sustainability

- An optimal cut improves ventilation and plant health by reducing the use of phytosanitary products.
- The low power required allows the use of small tractors with a lower carbon footprint.
- Sustainable consumption: Equipment designed to be up-to-date and have a long service life.

Standard Equipment

- Anti-shock safety system.
- Sliding tray "no grease" with adjustable nylon wheels.
- Hydraulic lifting.
- Hydraulic inclination.
- Hydraulic parallelogram lateral displacement.
- Reciprocating cutting bars with excentric crankshaft.
- Storage foot.
- Adaptable standard plate to tractor (frontal).
- Lateral support rods.

Remote control type

ID-PLUS

- Includes ID-CONTROL multifunction joystick.
- Includes an electronic microcontroller: allows software updates at any time.
- Max 2-3 additional electro-hydraulic functions (depending on model).
- Includes a modular electro-hydraulic system: it allows to increase the number of electro-hydraulic functions.



ID-MICRO

- ! NOT included the ID-CONTROL multifunction joystick.
- Only for customers who already have the ID-CONTROL multifunction joystick.
- Includes an electronic microcontroller: allows software updates at any time.
- Max 2-3 additional electro-hydraulic functions (depending on model).
- Includes a modular electro-hydraulic system: it allows to increase the number of electro-hydraulic functions.

	ID-PLUS	ID-MICRO			
	REF.	REF.	A (m)	B (m)	X (m)
PV-L L SHAPE CANE TRIMMER FOR VINEYARD AND OLIVES TREES CUT, EXTENSION, MODULE TILT, MODULE LIFT	PVL-EP-1710-1	PVL-EP-1710-2	1,75	1,00	2,20-2,80
	PVL-EP-2010-1	PVL-EP-2010-2	2,00	1,00	
 CUT, EXTENSION, MODULE TILT, MODULE LIFT, HORIZONTAL BAR LIFT	PVL-TE-1710-1	PVL-TE-1710-2	1,75	1,00	1,50-2,60
	PVL-TE-2010-1	PVL-TE-2010-2	2,00	1,00	
 CUT, EXTENSION, MODULE TILT, MODULE LIFT, HORIZONTAL BAR LIFT	PVL-LA-1710-1	PVL-LA-1710-2	1,75	1,00	2,20-2,80
	PVL-LA-2010-1	PVL-LA-2010-2	2,00	1,00	

PV-L
Pre-pruning, pruning and leaf stripping

Remote control type

		X	Y	Z	A	B			L	W	H
	REF.	m	m	m	m	m	kg	HP	m	m	m
PV-L	PVL-EP-1710	2,20-2,80	0,45-1,30	1,40-2,20	1,75	1,00	380	60	1,30	0,80	2,30
	PVL-EP-2010	2,20-2,80	0,45-1,30	1,40-2,20	2,00	1,00	400	60	1,30	0,80	2,55
	PVL-TE-1710	1,50-2,60	0,45-1,30	1,40-2,20	1,75	1,00	400	60	1,30	0,80	2,30
	PVL-TE-2010	1,50-2,60	0,45-1,30	1,40-2,20	2,00	1,00	415	60	1,30	0,80	2,55
	PVL-LA-1710	2,20-2,80	0,45-1,30	1,40-2,20	1,75	1,00	400	60	1,30	0,80	2,30
	PVL-LA-2010	2,20-2,80	0,45-1,30	1,40-2,20	2,00	1,00	415	60	1,30	0,80	2,55

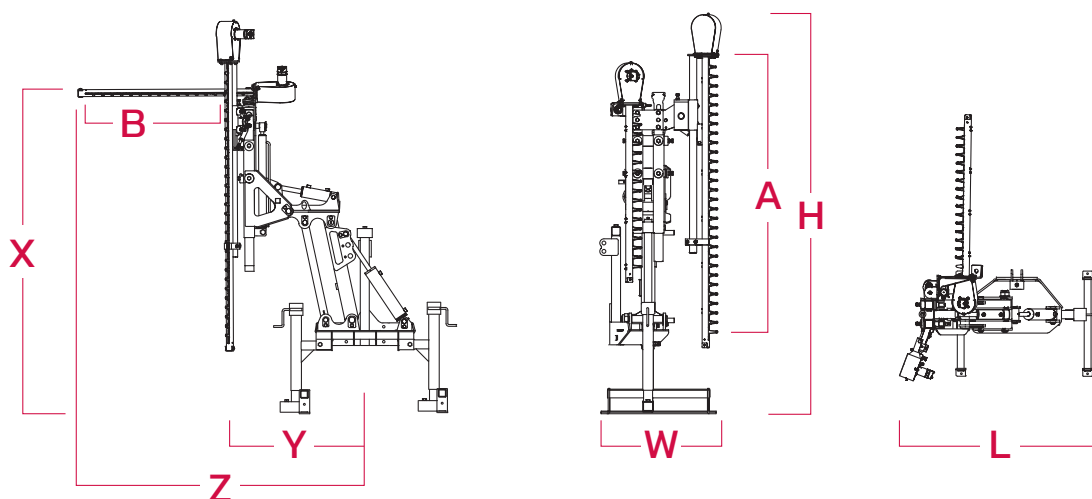

Tractor mounting



Tractor connection and assembling

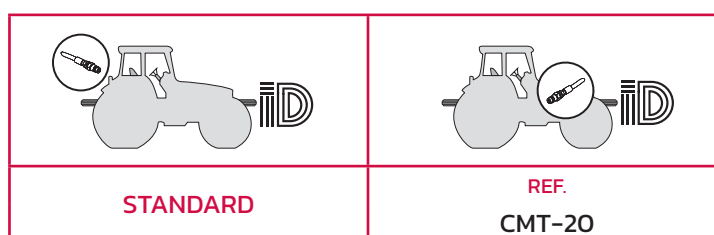

Cane trimmer Accessories and Options

📷	DESCRIPTION	OBSERVATIONS		REF.
	Hydraulic power unit 60 L to 3 Point linkage	Pump 35 liters		C12
	Standard oil cooler	Adaptable to 60 lt hydraulic power plant		A15-60
	Protective screen of the blades PV	Bar 1,00 m		PC-02
		Bar 1,75 m		PC-03
		Bar 2,00 m		PC-04
	Hydraulic lower vine shoot lifter	Tilting Adjustable	Right	LSN-D
	3-point coupling kit	Front 3P or reversible tractor		T2P-10
	Plate for front tractor coupling	It will be supplied only if the corresponding form has been correctly filled out		PA-F
	Packaging	Basic		EMB-1
		Airfreight- oceanfreight		EMB-2



Our 3-keys Ideology

Organizational culture

We focused on Lean Manufacturing philosophy to improve operations management, products and workspaces

The Agile Methodology provides us a way to develop better projects in a faster manner, involving and organizing staff to operate as a whole

Design is our attitude and Design Thinking is the tool to face challenges and solve problems, designing products and services focused on users, involving them in the creative process

Mindset
ID



INDUSTRIAS DAVID S.L.U.
C/ Médico Miguel Lucas s/n
CP: 30510, Yecla, Murcia-Spain
Tel.: +34 968 718 119
info@id-david.com

Connect with us.
[instagram.com/iddavid_official](https://www.instagram.com/iddavid_official)
twitter.com/IDdavidslu
[facebook.com/industriasdavid](https://www.facebook.com/industriasdavid)
[linkedin.com/company/id-david](https://www.linkedin.com/company/id-david)
[youtube.com/industriasdavid](https://www.youtube.com/industriasdavid)

www.id-david.com

