

NAKIRI

EN

Tunnel precision pruner

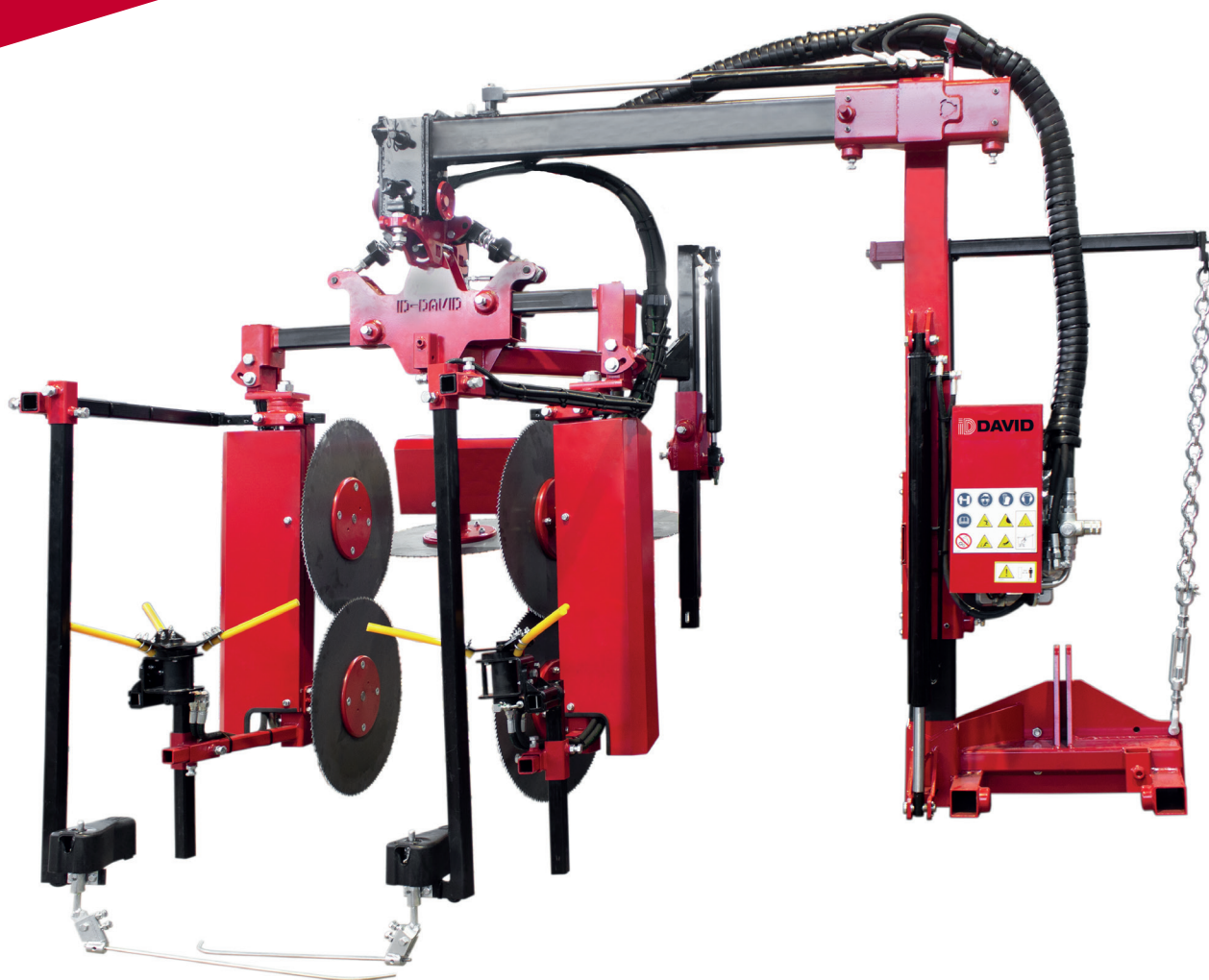

SERIE

NAKIRI



Tunnel precision pruner. Pruning equipment designed for precision cutting in berries, blueberries and vineyards on trellis system with posts that do not exceed the cordon line, drastically reducing or even entirely avoiding the manual operations.

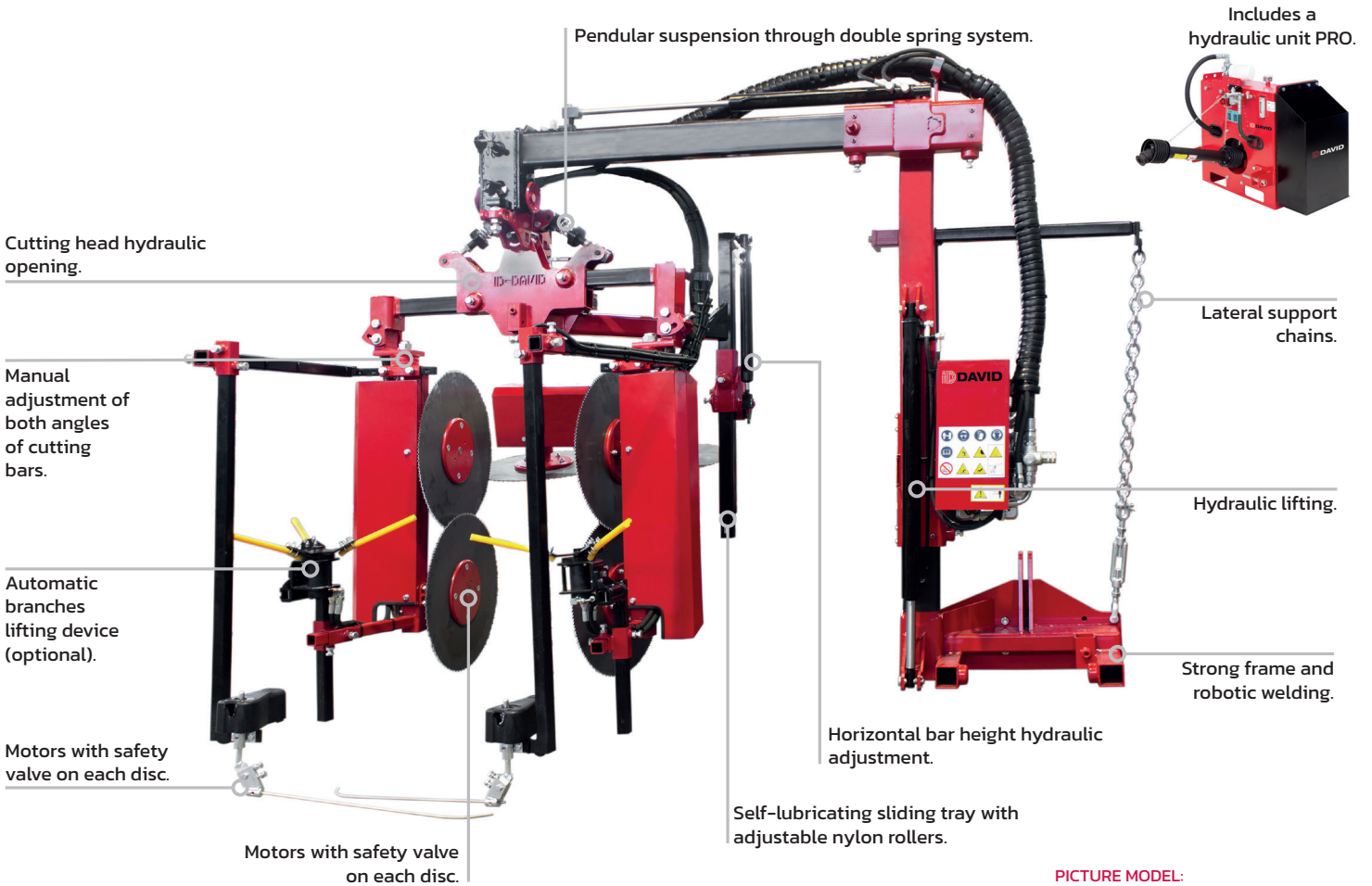

PICTURE MODEL:
MPT + AL-H-01 + PAC-01



Versatility

- The ID-CONTROL joystick allows to control all the machines manufactured by ID David and equipped with the ID-PLUS or ID-MICRO technology.
- Models adjustable to any kind of plantation system.

Exclusivity

- The first and unique range of pruners in the world equipping each disc with independent hydraulic motors since 2001.
- Automatic row guidance vs automatic self-centering system on the row (optional).
- Vine shoots, hanging or climbing branches lifter.

Effectiveness

- Electrohydraulic system optimized for extremely low power consumption.
- Cutting elements supported by years of experience in the market.
- Correct evacuation of the remains of the pruning.

Reliability

- Components and materials of high quality.
- Low maintenance. No lubrication in its essential parts.
- Motors with safety valve and automatic reset in case of a shut down.

Safety

- Maintains a constant verticality of the cutting head by the exclusive pendular suspension system that absorbing the ground irregularities.

Sustainability

- Our painting is lead-free and without toxic pigments.
- The low power required allows the use of small tractors with a lower carbon footprint.
- Sustainable consumption: Equipment designed to be up-to-date and have a long service life.

Standard Equipment

- Anti-shock security fuse.
- Hydraulic lifting.
- Hydraulic width adjusting.
- Hydraulic adjustment between modules of vertical cut.
- Pendular suspension by means of a double spring.
- Storage foot.
- Includes a PRO hydraulic unit with cooler and quick couplings.
- Adaptable standard plate to tractor (frontal).
- Lateral support chains.
- Cutting discs Ø600 x 160 teeth.

Remote control type



ID-PLUS

- Includes ID-CONTROL multifunction joystick.
- Includes an electronic microcontroller: allows software updates at any time.
- Up to 2 additional electro-hydraulic functions.

ID-MICRO

! NOT included the ID-CONTROL multifunction joystick.

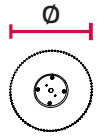
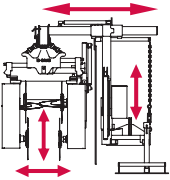

- Only for customers who already have the ID-CONTROL multifunction joystick.
- Includes an electronic microcontroller: allows software updates at any time.
- Up to 2 additional electro-hydraulic functions.

NAKIRI	ID-PLUS 	ID-MICRO 	
	REF.	REF.	N° DISCS
 <p>CUTTING, OPENING, LIFTING, EXTENSION, HORIZONTAL CUTTING BAR LIFTING</p>	MPT-1	MPT-2	2+2+2 Ø600

NAKIRI
Pre-pruning, pruning and leaf stripping



Technical details

		X	Y	A	B			L	W	H
NAKIRI	REF.	m	m	m	m	kg	HP	m	m	m
PRECISION PRUNER FOR VINEYARD	MPT	0,85-2,10	1,05-1,80	1,10	0,10-0,75	840	70	2,40	1,40	2,40

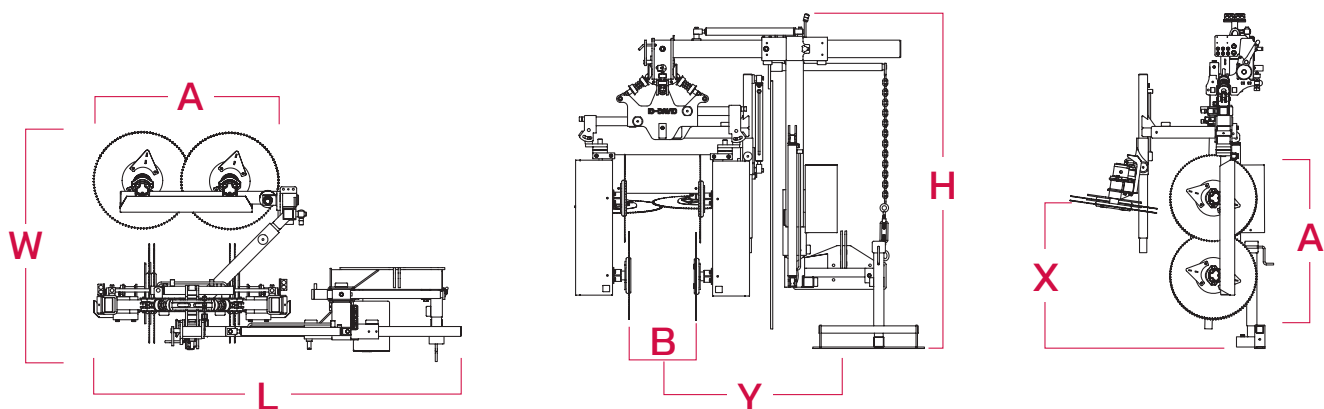

Tractor mounting



Pruner Accessories and Options

	DESCRIPTION	OBSERVATIONS	REF.
	Sensor rod self-centering		PAC-01
	Hydraulic lower vine shoot lifter	Tilting Adjustable	AL-H-01
	Cutting disc Ø600 150 teeth	Unit	D-Z150
	Counterweight box	Can be coupled to a hydraulic power plant of 80 or 150 lt	CPM-01
	3 Points linkage	Front 3P or reversible tractor	T3P-15
	Plate for front tractor coupling	It will be supplied only if the corresponding form has been correctly filled out	PA-F
	Packaging	Basic	EMB-1
		Airfreight- oceanfreight	EMB-2

Our 3-keys Ideology Organizational culture

We focused on Lean Manufacturing philosophy to improve operations management, products and workspaces

The Agile Methodology provides us a way to develop better projects in a faster manner, involving and organizing staff to operate as a whole

Design is our attitude and Design Thinking is the tool to face challenges and solve problems, designing products and services focused on users, involving them in the creative process

Mindset
ID



INDUSTRIAS DAVID S.L.U.
C/ Médico Miguel Lucas s/n
CP: 30510, Yecla, Murcia-Spain
Tel.: +34 968 718 119
info@id-david.com

Connect with us.
[instagram.com/iddavid_official](https://www.instagram.com/iddavid_official)
twitter.com/IDdavidslu
[facebook.com/industriasdavid](https://www.facebook.com/industriasdavid)
[linkedin.com/company/id-david](https://www.linkedin.com/company/id-david)
[youtube.com/industriasdavid](https://www.youtube.com/industriasdavid)

www.id-david.com

