

V1

EN

Polyvalent discs pruner



SETO



ARBO



DAVID
SMART FARMING SOLUTIONS

SERIE V1



Polyvalent discs pruner. Ideal for vertical and horizontal pruning from an height 0.75 m in traditional, intensive and V-hedge fruit crops.

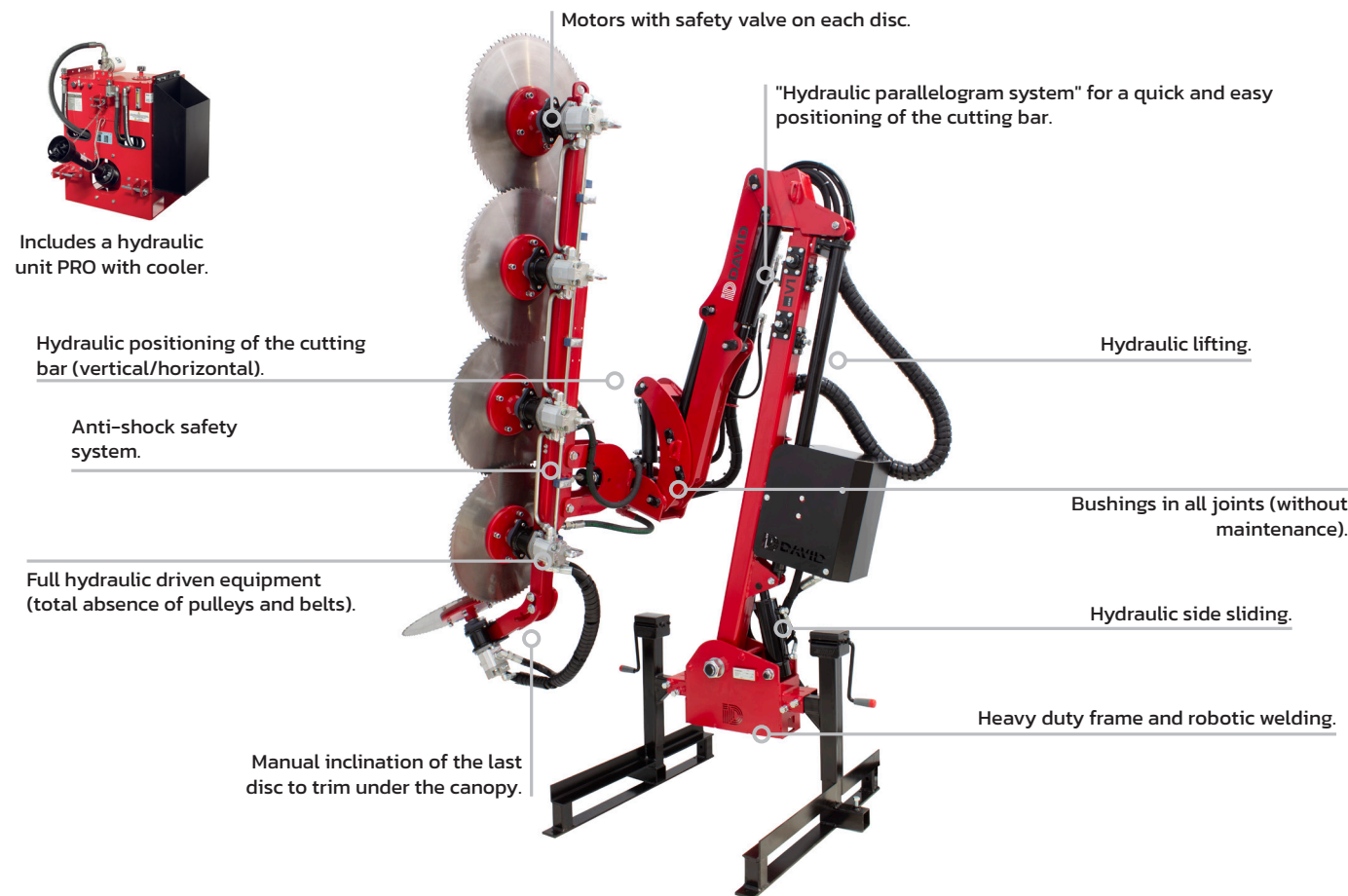

PICTURE MODEL:
V1-5D



Versatility

- Different models of discs to guarantee quality and cutting power adapted to each type and intensity of pruning.
- The ID-CONTROL joystick allows to control all the machines manufactured by ID David and equipped with the ID-PLUS or ID-MICRO technology.
- Models adjustable to any kind of plantation system.

Exclusivity

- The first and unique range of pruners in the world equipping each disc with independent hydraulic motors since 2001.
- Hydraulic parallelogram system for a quick and easy positioning of the cutting bar.
- Electronic indication for RPM of cutting disc (optional).

Effectiveness

- Electrohydraulic system optimized for extremely low power consumption.
- Correct evacuation of the remains of the pruning.
- High cutting capacity up to 20 cm.

Reliability

- Components and materials of high quality.
- Low maintenance. No lubrication in its essential parts.
- Manufacturing experience since 1983.

Safety

- Anti-shock safety system.
- Motors with safety valve and automatic reset in case of a shut down.
- Great vision during working phase.

Sustainability

- Our painting is lead-free and without toxic pigments.
- The low power required allows the use of small tractors with a lower carbon footprint.
- Sustainable consumption: Equipment designed to be up-to-date and have a long service life.

Standard Equipment

- 1 Motor + safety valve on each disc.
- Hydraulic lifting.
- Hydraulic sideshift.
- Hydraulic positioning of the cutting bar.
- Hydraulic inclination.
- Hardened steel 86 teeth-disc.
- Progressive starting of motors.
- Safety system with automatic reset.
- Includes a PRO hydraulic unit with cooler and quick couplings.
- Storage foot.
- Adaptable standard plate to tractor (frontal).
- Lateral support rods.

Remote control type

ID-PLUS

- Includes ID-CONTROL multifunction joystick.
- Includes an electronic microcontroller: allows software updates at any time.
- Max 1 additional electro-hydraulic function.
- Includes a modular electro-hydraulic system: it allows to increase the number of electro-hydraulic functions.

ID-MICRO

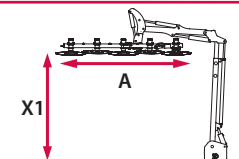
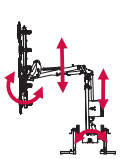

- ! NOT included the ID-CONTROL multifunction joystick.
- Only for customers who already have the ID-CONTROL multifunction joystick.
- Includes an electronic microcontroller: allows software updates at any time.
- Max 1 additional electro-hydraulic function.
- Includes a modular electro-hydraulic system: it allows to increase the number of electro-hydraulic functions.

	ID-PLUS	ID-MICRO	\emptyset		
V1	REF.	REF.	N° DISCS	A (m)	X1 (m)
 CUT, DISPLACEMENT, LIFT, PARALLELOGRAM LIFT OF MODULE, MODULE TILT	V1-5D-1	V1-5D-2	5 Ø600 mm	2,75	0,70-4,05
	V1-6D-1	V1-6D-2	6 Ø600 mm	3,25	

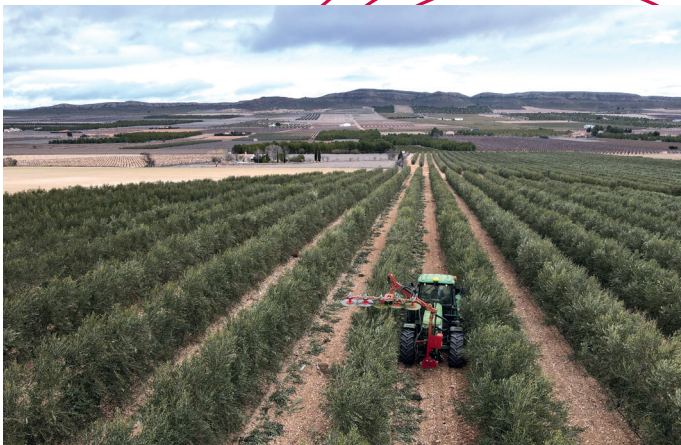
V1
Pre-pruning, pruning and
leaf stripping



Technical details

	X1	Y1	X2	Y2	A			L	W	H	
REF.	m	m	m	m	m	kg	HP	m	m	m	
V1	V1-5D	0,70-4,05	1,90-4,50	3,00-6,20	0,60-2,20	2,75	590	60	1,65	1,50	2,95
	V1-6D	0,70-4,05	2,40-5,00	3,50-6,70	0,60-2,20	3,25	620	70	1,65	1,50	3,50

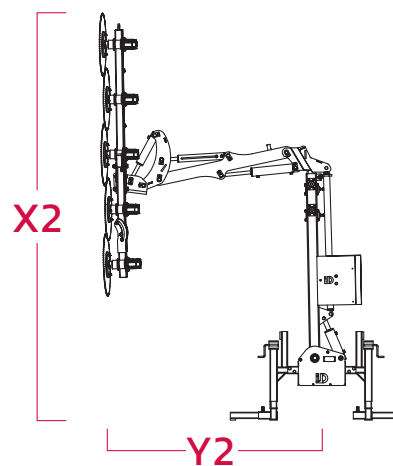
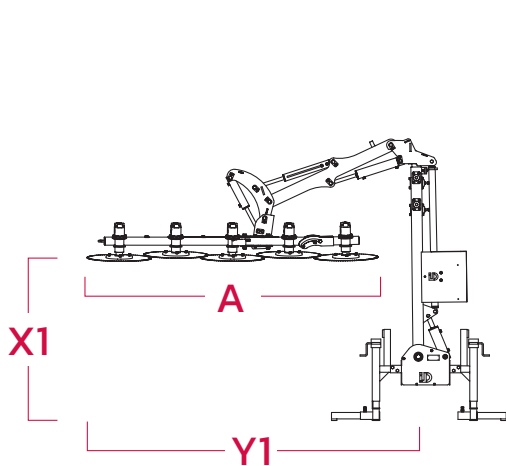
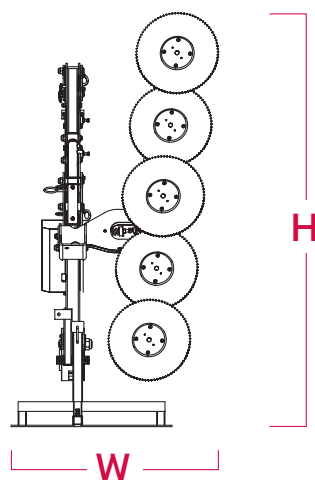
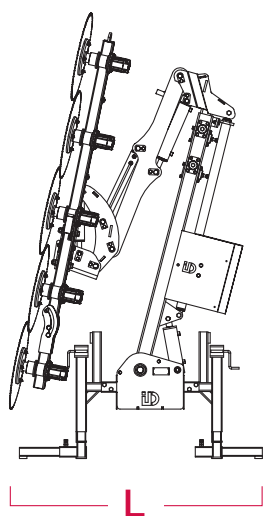

Tractor mounting



Basic kit to be adapted to new equipment - option

Recommended kit for interior tree trimming ("V" cut) and skirting in fruit trees - option

📷	OBSERVATIONS	REF.
	Cutting bar tilting cylinder for V - cut and skirt cut.	POR-5

Prepruner

Accessories and Options

📷	DESCRIPTION	OBSERVATIONS	REF.
	Cutting disc type HOZ: specific for almond trees		1,5 cm D-Z2H-R
	Knife discs for green branches with suction system	Right	1,5 cm D-Z4-D
	Knife discs for green branches with suction system	Left for equipments with MTR-5 MTR-6	1,5 cm D-Z4-I
	Hardened steel 150 teeth-disc	Thin branches or fibrous materials	3 cm D-Z150
	Hardened steel 100 teeth-disc		5 cm D-Z100
	Hardened steel 86 teeth-disc	Standard included	8 cm D-Z86
	DAVISC 40 notched-Disc		20 cm DA-Z40
	RPM electronic counter of cutting disc		IE-RPM
	Plate for front tractor coupling	It will be supplied only if the corresponding form has been correctly filled out	PA-F
	Reinforced 3 Points linkage	Front 3P or reversible tractor	T3P-11
	Sharpening tool		M-A

	DESCRIPTION	OBSERVATIONS	REF.
	Sharpening disc replacement	For HSS disc and DAVIS disc	D-AA
	Disinfectant application kit	For 5 discs cutting bar	K-AD-5
		Includes 200L stainless steel tank and electric pump	
		For 6 discs cutting bar	K-AD-6
	INOX 200 L additional tank for disinfectant kit	Possibility of adapting up to 2 units	KDD20
	Protective screen of the cutting bar	For 5 discs cutting bar	Unit PAP-5D6
		For 6 discs cutting bar	Unit PAP-6D6
	*Recommended with disinfection kit		
	Disc protective screen		Unit PD-D6
	Kit Reversibles motors	Only for V-hedge trees	5 Units MTR-5
			6 Units MTR-6
	*Replaces standard.		
	Storage Wheel Kit	For hydraulic power plant	KRCH
	Packaging	Basic	EMB-1
		Airfreight- oceanfreight	EMB-3

Inherent in our DNA

We use technology to create technology.
Our commitment to the digitization and versatility of our equipment has led to the creation of our exclusive ID PLUS system which allows the control of all ID machines through a simple Plug & Play Joystick.



INDUSTRIAS DAVID S.L.U.
C/ Médico Miguel Lucas s/n
CP: 30510, Yecla, Murcia-Spain
Tel.: +34 968 718 119
info@id-david.com

Connect with us.
[instagram.com/iddavid_official](https://www.instagram.com/iddavid_official)
twitter.com/IDdavidslu
[facebook.com/industriasdavid](https://www.facebook.com/industriasdavid)
[linkedin.com/company/id-david](https://www.linkedin.com/company/id-david)
[youtube.com/industriasdavid](https://www.youtube.com/industriasdavid)

www.id-david.com

