

ID-REX

EN

Polyvalent high discs pruner



SERIE

ID-REX



Polyvalent high discs pruner. Ideal for lateral and topping pruning in traditional and intensive plantations of fruit trees.



Includes a hydraulic unit PRO with cooler.

Hydraulic positioning of the cutting bar (vertical/horizontal).

Anti-shock safety system.

Full hydraulic driven equipment (total absence of pulleys and belts).

Manual inclination of the last disc to trim under the canopy.

Motors with safety valve on each disc.

"Hydraulic parallelogram system" for a quick and easy positioning of the cutting bar.

Reinforced frame.

Hydraulic lifting.

Bushings in all joints (without maintenance).

Hydraulic side sliding.

Heavy duty frame and robotic welding.

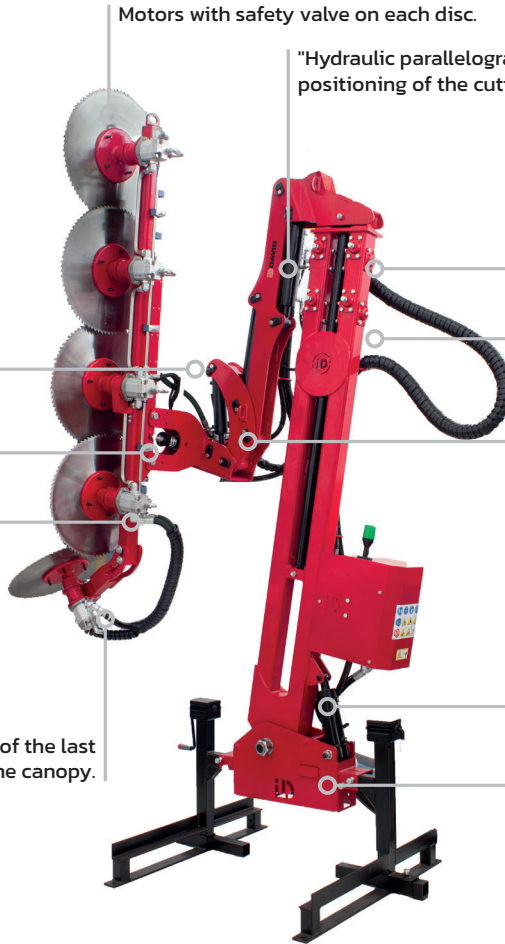

PICTURE MODEL:
V1-HD-5D + IE-RPM

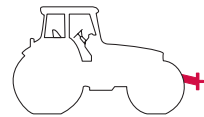

Versatility

- Different models of discs to guarantee quality and cutting power adapted to each type and intensity of pruning.
- The ID-CONTROL joystick allows to control all the machines manufactured by ID David and equipped with the ID-PLUS or ID-MICRO technology.
- Models adjustable to any kind of plantation system.

Exclusivity

- The first and unique range of pruners in the world equipping each disc with independent hydraulic motors since 2001.
- Hydraulic parallelogram system for a quick and easy positioning of the cutting bar.
- Electronic indication for RPM of cutting disc (optional).

Effectiveness

- Electrohydraulic system optimized for extremely low power consumption.
- Correct evacuation of the remains of the pruning.
- High cutting capacity up to 20 cm.

Reliability

- Components and materials of high quality.
- Low maintenance. No lubrication in its essential parts.
- Manufacturing experience since 1983.

Safety

- Anti-shock safety system.
- Motors with safety valve and automatic reset in case of a shut down.
- Great vision during working phase.

Sustainability

- Our painting is lead-free and without toxic pigments.
- The low power required allows the use of small tractors with a lower carbon footprint.
- Sustainable consumption: Equipment designed to be up-to-date and have a long service life.

Standard Equipment

- 1 Motor + safety valve on each disc.
- Hydraulic lifting.
- Hydraulic sideshift.
- Hydraulic positioning of the cutting bar.
- Hydraulic inclination.
- Hardened steel 86 teeth-disc.
- Progressive starting of motors.
- Safety system with automatic reset.
- Includes a PRO hydraulic unit with cooler and quick couplings.
- Storage foot.
- Adaptable standard plate to tractor (frontal).
- Lateral support rods.

Remote control type

ID-PLUS

- Includes ID-CONTROL multifunction joystick.
- Includes an electronic microcontroller: allows software updates at any time.
- Max 1 additional electro-hydraulic function.
- Includes a modular electro-hydraulic system: it allows to increase the number of electro-hydraulic functions.

ID-MICRO



- ! NOT included the ID-CONTROL multifunction joystick.
- Only for customers who already have the ID-CONTROL multifunction joystick.
- Includes an electronic microcontroller: allows software updates at any time.
- Max 1 additional electro-hydraulic function.
- Includes a modular electro-hydraulic system: it allows to increase the number of electro-hydraulic functions.

ID-REX	ID-PLUS	ID-MICRO	\emptyset		
	REF.	REF.	N° DISCS	A (m)	X1 (m)
<p>CUT, DISPLACEMENT, LIFT, PARALLELOGRAM LIFT OF MODULE, MODULE TILT</p>	V1-SHD-5D-1	V1-SHD-5D-2	5 Ø600 mm	2,75	0,70-4,05
	V1-SHD-6D-1	V1-SHD-6D-2	6 Ø600 mm	3,25	
	V1-MHD-5D-1	V1-MHD-5D-2	5 Ø600 mm	2,75	1,00-4,70
	V1-MHD-6D-1	V1-MHD-6D-2	6 Ø600 mm	3,25	
	V1-HD-5D-1	V1-HD-5D-2	5 Ø600 mm	2,75	1,40-5,10
	V1-HD-6D-1	V1-HD-6D-2	6 Ø600 mm	3,25	

ID-REX
Pre-pruning, pruning and
leaf stripping



Technical details

REF.	X1	Y1	X2 (Max)	Y2	X3 (Min)	A			L	W	H	
	m	m	m	m	m	m	kg	HP	m	m	m	
ID-REX	V1-SHD-5D	0,70-4,05	2,00-4,40	6,20	0,60-2,20	0,30	2,75	800	90	1,75	1,50	3,00
	V1-SHD-6D	0,70-4,05	2,50-4,90	6,70	0,60-2,20	0,30	3,25	830	100	1,75	1,50	3,50
	V1-MHD-5D	1,00-4,70	2,00-4,40	6,85	0,60-2,60	0,50	2,75	825	90	1,75	1,50	3,40
	V1-MHD-6D	1,00-4,70	2,50-4,90	7,35	0,60-2,60	0,50	3,25	855	100	1,75	1,50	3,90
	V1-HD-5D	1,40-5,10	2,00-4,40	7,25	0,60-2,60	0,90	2,75	840	90	1,75	1,50	3,80
	V1-HD-6D	1,40-5,10	2,50-4,90	7,75	0,60-2,60	0,90	3,25	870	100	1,75	1,50	4,30

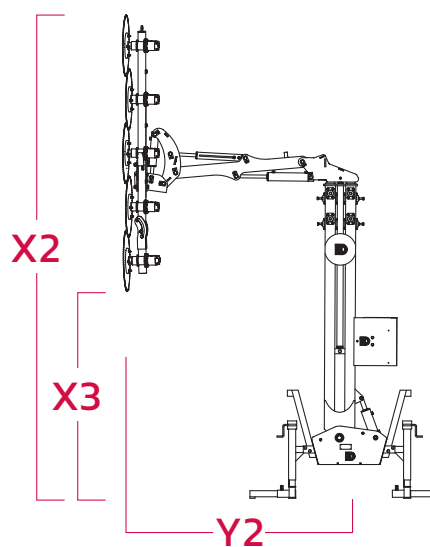
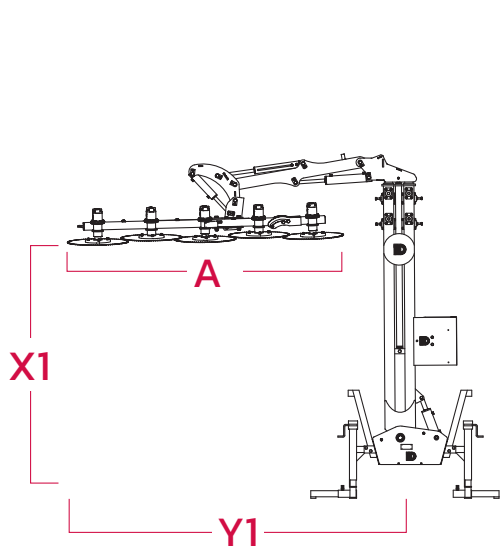
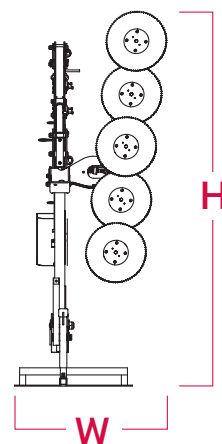
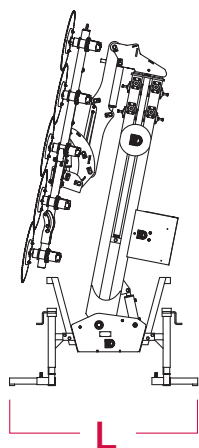

Tractor mounting



Prepruner Accessories and Options

📷	DESCRIPTION	OBSERVATIONS	REF.
	Cutting disc type HOZ: specific for almond trees		D-Z2H-R
	Knife discs for green branches with suction system	Right	
	Hardened steel 150 teeth-disc	Thin branches or fibrous materials	
	Hardened steel 100 teeth-disc		
	Hardened steel 86 teeth-disc	Standard included	
	DAVISC 40 notched-Disc		
	RPM electronic counter of cutting disc		IE-RPM
	Plate for front tractor coupling	It will be supplied only if the corresponding form has been correctly filled out	PA-F
	Reinforced 3 Points linkage	Front 3P or reversible tractor	T3P-11
	Sharpening tool		M-A
	Sharpener disc replacement	For HSS disc and DAVISC disc	D-AA
	Disinfectant application kit	For 5 discs cutting bar	K-AD-5
		For 6 discs cutting bar	K-AD-6
	INOX 200 L additional tank for disinfectant kit	Possibility of adapting up to 2 units	KDD20
	Protective screen of the cutting bar	For 5 discs cutting bar	Unit
		For 6 discs cutting bar	Unit

*Recommended with disinfection kit

	DESCRIPTION	OBSERVATIONS	REF.
	Disc protective screen	Unit	PD-D6
	Storage Wheel Kit	For hydraulic power plant	KRCH
	Packaging	Basic	EMB-1
		Airfreight- oceanfreight	EMB-3

Inherent in our DNA

We use technology to create technology.
Our commitment to the digitization and versatility of our equipment has led to the creation of our exclusive ID PLUS system which allows the control of all ID machines through a simple Plug & Play Joystick.



INDUSTRIAS DAVID S.L.U.
C/ Médico Miguel Lucas s/n
CP: 30510, Yecla, Murcia-Spain
Tel.: +34 968 718 119
info@id-david.com

Connect with us.
[instagram.com/iddavid_official](https://www.instagram.com/iddavid_official)
twitter.com/IDdavidslu
[facebook.com/industriasdavid](https://www.facebook.com/industriasdavid)
[linkedin.com/company/id-david](https://www.linkedin.com/company/id-david)
[youtube.com/industriasdavid](https://www.youtube.com/industriasdavid)

www.id-david.com

