

V5

EN

Discs compact pruner



SERIE V5



Discs compact pruner. Ideal for side and topping pruning in intensive fruit crops and hedges planted narrow rows.

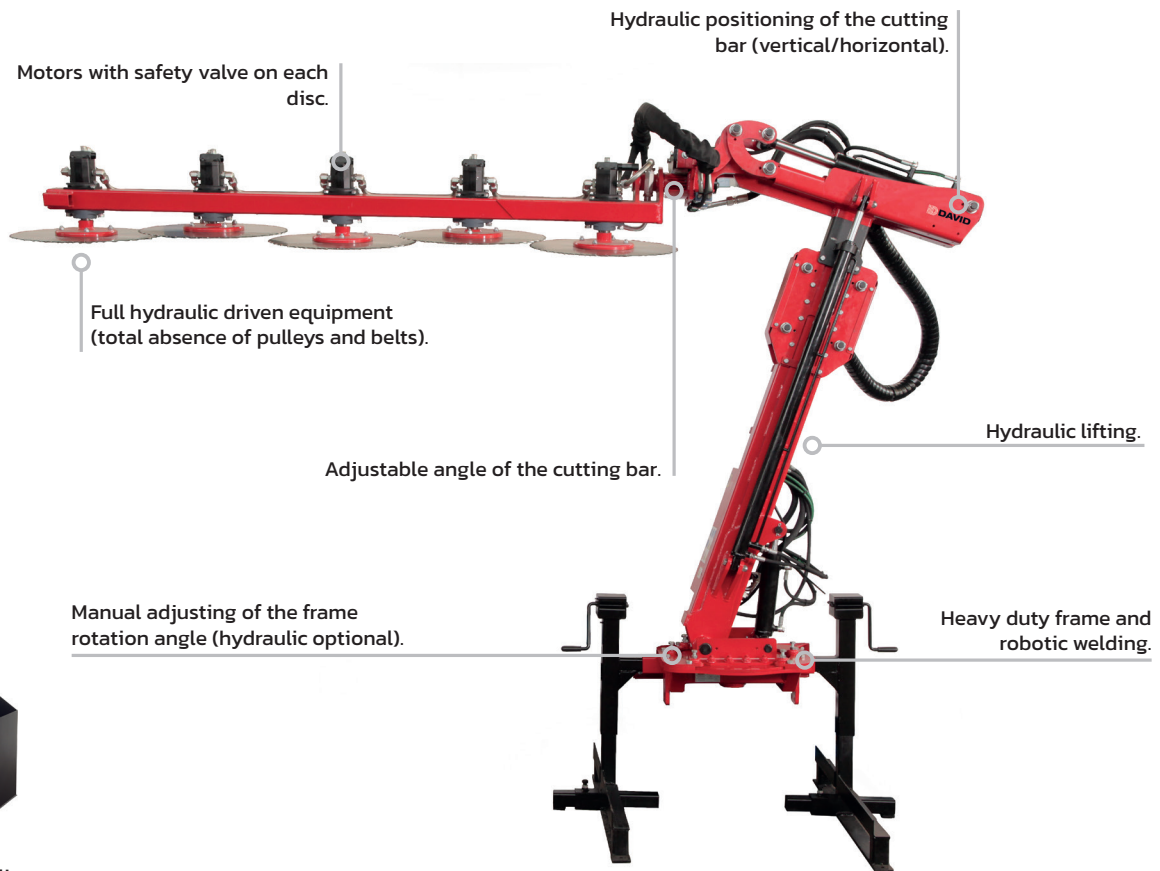

Includes a hydraulic unit PRO with cooler.

PICTURE MODEL:
V5-5D + DA-Z40



Versatility

- Different models of discs to guarantee quality and cutting power adapted to each type and intensity of pruning.
- The ID-CONTROL joystick allows to control all the machines manufactured by ID David and equipped with the ID-PLUS or ID-MICRO technology.
- Models adjustable to any kind of plantation system.

Exclusivity

- The first and unique range of pruners in the world equipping each disc with independent hydraulic motors since 2001.
- Thanks to its turning frame it is possible to work with the cutting bar positioned to the right or left of the tractor, being able to determine the cutting direction and the place of evacuation of the branches.

Effectiveness

- Electrohydraulic system optimized for extremely low power consumption.
- Correct evacuation of the remains of the pruning.
- High cutting capacity up to 20 cm.
- Electronic indication for RPM of cutting disc (optional).

Reliability

- Components and materials of high quality.
- Low maintenance. No lubrication in its essential parts.
- Manufacturing experience since 1983.

Safety

- Motors with safety valve and automatic reset in case of a shut down.
- Great vision during working phase.

Sustainability

- Our painting is lead-free and without toxic pigments.
- The low power required allows the use of small tractors with a lower carbon footprint.
- Sustainable consumption: Equipment designed to be up-to-date and have a long service life.

Standard Equipment

- 1 Motor + safety valve on each disc.
- Hydraulic lifting.
- Hydraulic turn of cutting bar.
- Manual turning central frame (cutting left/right and branches discharge).
- Hydraulic sideshift.
- Horizontal bar hydraulic inclination.
- Hardened steel 86 teeth-disc.
- Progressive starting of motors.
- Includes a PRO hydraulic unit with cooler and quick couplings.
- Storage foot.
- Adaptable standard plate to tractor (frontal).
- Lateral support rods.



Remote control type

ID-PLUS

- Includes ID-CONTROL multifunction joystick.
- Includes an electronic microcontroller: allows software updates at any time.
- Max 1 additional electro-hydraulic function.
- Includes a modular electro-hydraulic system: it allows to increase the number of electro-hydraulic functions.

ID-MICRO

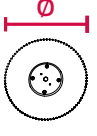
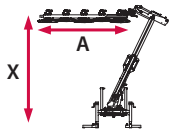

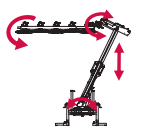
- ! NOT included the ID-CONTROL multifunction joystick.
- Only for customers who already have the ID-CONTROL multifunction joystick.
- Includes an electronic microcontroller: allows software updates at any time.
- Max 1 additional electro-hydraulic function.
- Includes a modular electro-hydraulic system: it allows to increase the number of electro-hydraulic functions.

	ID-PLUS	ID-MICRO				
						
	REF.	REF.	N° DISCS	A (m)	X (m)	
V5						
	V5-4D-1	V5-4D-2	4 Ø600 mm	2,25	2,00-3,40	
	V5-5D-1	V5-5D-2	5 Ø600 mm	2,75	2,00-3,40	
	V5X-5D-1	V5X-5D-2	5 Ø600 mm	2,75	2,50-4,00	
CUTTING, TILTING, LIFTING, CUTTING BAR INCLINATION, CUTTING BAR TURN	V5XX-5D-1	V5XX-5D-2	5 Ø600 mm	2,75	3,00-4,50	

V5
Pre-pruning, pruning and
leaf stripping



Technical details

	REF.	X	Y	A			L	W	H
		m	m	m	kg	HP	m	m	m
V5	V5-4D	2,00-3,40	1,70-4,10	2,25	660	60	2,30	1,00	2,60
	V5-5D	2,00-3,40	2,20-4,60	2,75	700	70	3,00	1,00	2,60
	V5X-5D	2,50-4,00	2,00-4,90	2,75	850	90	2,60	1,00	2,90
	V5XX-5D	3,00-4,50	2,20-5,60	2,75	920	100	3,00	1,00	3,30

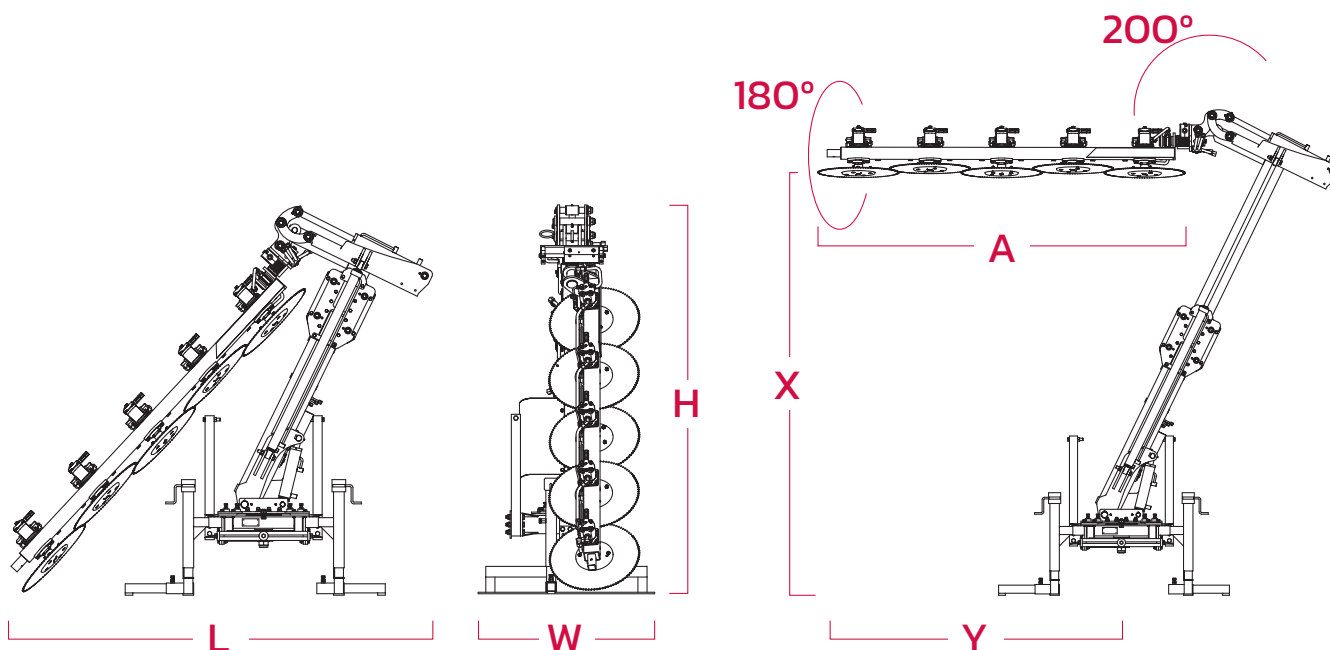

Tractor mounting



REF







STANDARD







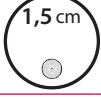











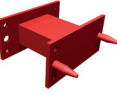
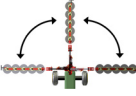



REF

LDT-5

Prepruner Accessories and Options

	DESCRIPTION	OBSERVATIONS	REF.
	Cutting disc type HOZ: specific for almond trees		D-Z2H-R
	Knife discs for green branches with suction system		D-Z4-D
	Hardened steel 150 teeth-disc	Thin branches or fibrous materials 	D-Z150

	DESCRIPTION	OBSERVATIONS	REF.
	Hardened steel 100 teeth-disc		D-Z100
	Hardened steel 86 teeth-disc	Standard included	 D-Z86
	DAVISC 40 notched-Disc		DA-Z40
	RPM electronic counter of cutting disc		IE-RPM
	Plate for front tractor coupling	It will be supplied only if the corresponding form has been correctly filled out	PA-F
	Hydraulic positioning of central chassis (rotating blades)		GHCP
	Manual articulation of the last disc		AM-D
	3 Points linkage for front PTO		T3P-12
	3PH + stabilizer wheels + Hydraulic power plant	For reversible tractors	 CH-3P
	Hydraulic three-point stabilizer with wheels	For tractors without third frontal point	 CH-01
	Sharpening tool		M-A
	Sharpener disc replacement	For HSS disc and DAVISC disc	D-AA
	Disc protective screen	Unit	PD-D6
	Storage Wheel Kit	For hydraulic power plant	KRCH
	Packaging	Basic	EMB-1
		Airfreight- oceanfreight	EMB-3

Inherent in our DNA

We use technology to create technology.
Our commitment to the digitization and versatility of our equipment has led to the creation of our exclusive ID PLUS system which allows the control of all ID machines through a simple Plug & Play Joystick.



INDUSTRIAS DAVID S.L.U.
C/ Médico Miguel Lucas s/n
CP: 30510, Yecla, Murcia-Spain
Tel.: +34 968 718 119
info@id-david.com

Connect with us.
[instagram.com/iddavid_official](https://www.instagram.com/iddavid_official)
twitter.com/IDdavidslu
[facebook.com/industriasdavid](https://www.facebook.com/industriasdavid)
[linkedin.com/company/id-david](https://www.linkedin.com/company/id-david)
[youtube.com/industriasdavid](https://www.youtube.com/industriasdavid)

www.id-david.com

