

PFP

EN

*Reinforced discs pruner
to assembly on loaders or
telehandlers*



SERIE PFP



Reinforced discs pruner to assembly on loaders or telehandlers, to be used to cut the side or top on fruits trees and for road maintenance and public areas.

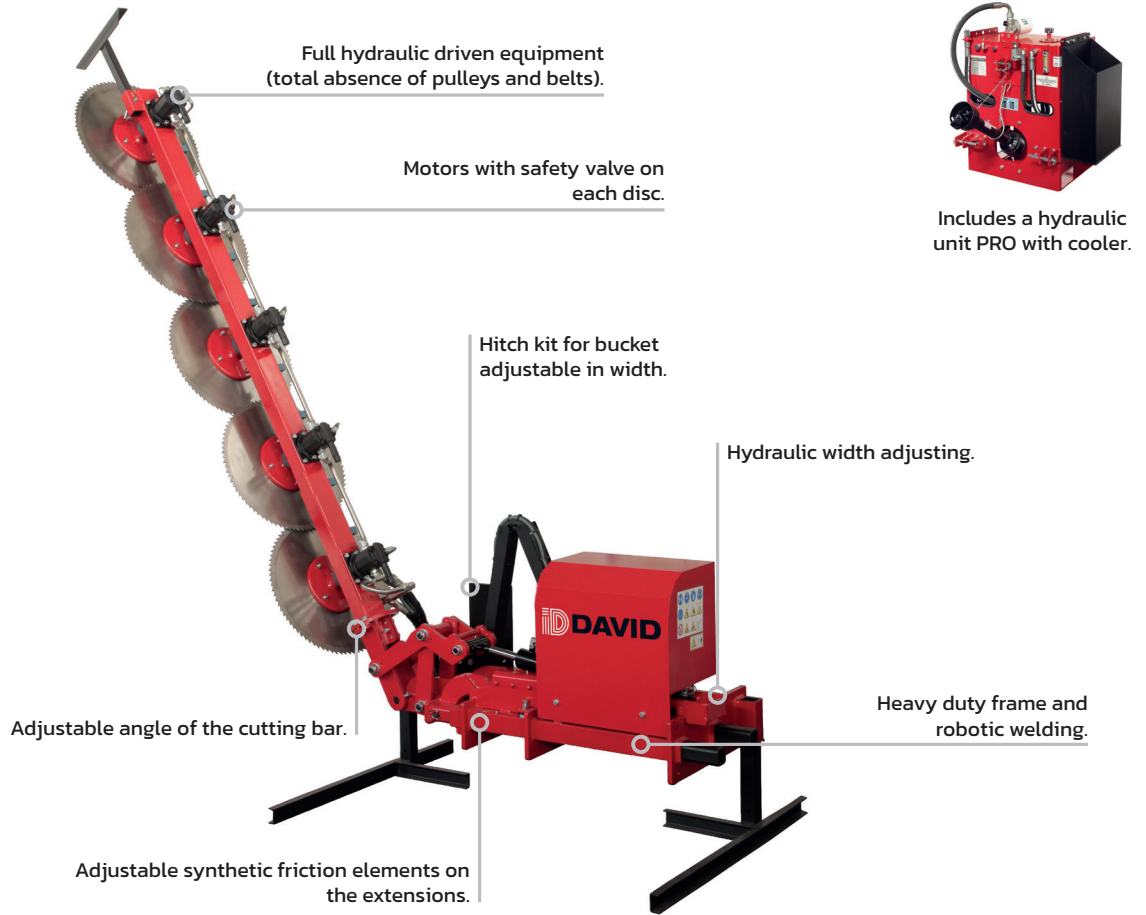

Includes a hydraulic unit PRO with cooler.

PICTURE MODEL:
PFP-5D

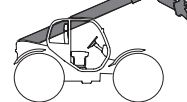

Versatility

- Different models of discs to guarantee quality and cutting power adapted to each type and intensity of pruning.
- The ID-CONTROL joystick allows to control all the machines manufactured by ID David and equipped with the ID-PLUS or ID-MICRO technology.
- Models adjustable to any kind of plantation system.

Reliability

- Components and materials of high quality.
- Low maintenance. No lubrication in its essential parts.
- Long life bearings due to lack of axial load.
- Manufacturing experience since 1983.

Exclusivity

- The first and unique range of pruners in the world equipping each disc with independent hydraulic motors since 2001.
- Electronic indication for RPM of cutting disc (optional).

Safety

- Anti-shock safety system.
- Motors with safety valve and automatic reset in case of a shut down.
- Great vision during working phase.

Effectiveness

- Electrohydraulic system optimized for extremely low power consumption.
- Correct evacuation of the remains of the pruning.
- High cutting capacity up to 20 cm.

Sustainability

- Our painting is lead-free and without toxic pigments.
- The low power required allows the use of small tractors with a lower carbon footprint.
- Sustainable consumption: Equipment designed to be up-to-date and have a long service life.

Standard Equipment

- 1 Motor + safety valve on each disc.
- Extendable hoses holder.
- Manual turn of cutting bar.
- Hydraulic width adjusting.
- Hydraulic sideshift.
- Complete cutting set hydraulic inclination.
- Hardened steel 86 teeth-disc.
- Progressive starting of motors.
- Includes a PRO hydraulic unit with cooler and quick couplings.
- Storage foot.
- Standard fixing plate to bucket.

Remote control type

ID-PLUS

- Includes ID-CONTROL multifunction joystick.
- Includes an electronic microcontroller: allows software updates at any time.
- Max 1 additional electro-hydraulic function.
- Includes a modular electro-hydraulic system: it allows to increase the number of electro-hydraulic functions.

ID-MICRO

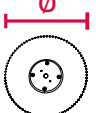
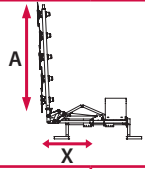
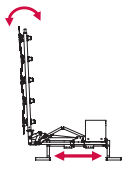

- ! NOT included the ID-CONTROL multifunction joystick.
- Only for customers who already have the ID-CONTROL multifunction joystick.
- Includes an electronic microcontroller: allows software updates at any time.
- Max 1 additional electro-hydraulic function.
- Includes a modular electro-hydraulic system: it allows to increase the number of electro-hydraulic functions.

PFP	ID-PLUS	ID-MICRO	 N° DISCS Ø600 mm	 A (m) X (m)	
	REF.	REF.		A (m)	X (m)
 CUT, EXTENSION, CUTTING BAR TILT	PFP-4D-1	PFP-4D-2	4 Ø600 mm	2,25	0,70
	PFP-5D-1	PFP-5D-2	5 Ø600 mm	2,75	
	PFP-6D-1	PFP-6D-2	6 Ø600 mm	3,25	

PFP Pre-pruning, pruning and leaf stripping



Technical details

		X	A			L	W	H
	REF.	m	m	kg	HP	m	m	m
PFP	PFP-4D	0,70	2,25	435	60	2,15	1,20	2,80
	PFP-5D	0,70	2,75	460	65	2,15	1,20	3,30
	PFP-6D	0,70	3,25	485	70	2,15	1,20	3,80

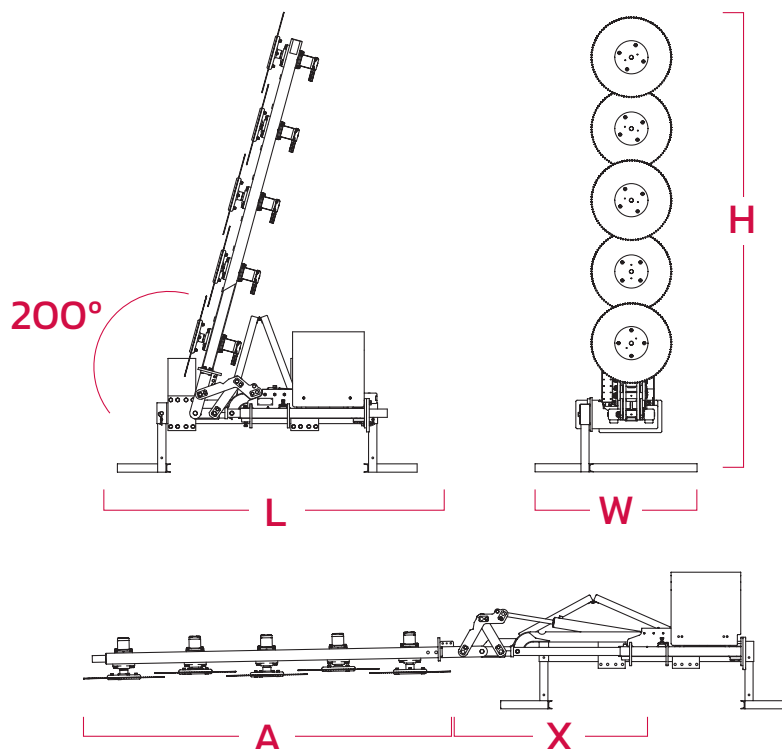

Tractor mounting



Basic kit for adaptation to new equipment - option

Recommended kit for telehandler - option

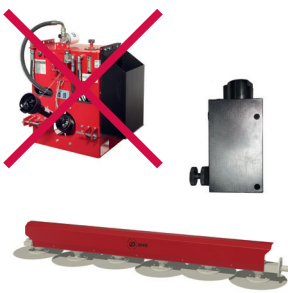
	OBSERVATIONS	REF.
	HYDRAULIC POWER ✗	This option modifies the pruner configuration, removing and adding components for direct connection to the telehandler: • Deduction of the hydraulic unit • Includes a flow divider up to 200 l / min • Includes motors protections • Includes hydraulic rings and hoses connection kit
	VALVE ✓	
	PROTECTIVE SCREEN ✓	
	COUPLING KIT ✓	
		POR-6

 By submitting an order for the optional "manipulator kit" pack, it is compulsory to submit the form n°4.

Prepuner Accessories and Options

📷	DESCRIPTION	OBSERVATIONS	REF.	
	Cutting disc type HOZ: specific for almond trees		D-Z2H-R	
	Knife discs for green branches with suction system		D-Z4-D	
	Hardened steel 150 teeth-disc	Thin branches or fibrous materials	D-Z150	
	Hardened steel 100 teeth-disc		D-Z100	
	Hardened steel 86 teeth-disc	Standard included	D-Z86	
	DAVISC 40 notched-Disc		DA-Z40	
	RPM electronic counter of cutting disc		IE-RPM	
	Hydraulic turn of cutting bar		GHMC	
	Quick hitch to front loader	Indicate frontloader brand and model	ER-PC	
	Manual articulation of the last disc		AM-D	
	Sharpening tool		M-A	
	Sharpener disc replacement	For HSS disc and DAVISC disc	D-AA	
	Disinfectant application kit	Includes 200L stainless steel tank and electric pump	K-AD-1	
	Disc protective screen	Unit	PD-D6	
	Storage Wheel Kit	For hydraulic power plant	KRCH	
	Kit Reversibles motors	Only for V-hedge trees	4 Units	MTR-4
			5 Units	MTR-5
			6 Units	MTR-6
	*Replaces standard.			

☐	DESCRIPTION	OBSERVATIONS	REF.
	Flow regulating valve * Mandatory for machines without hydraulic power unit	Up to 200L/min	VRC
	Packaging	Basic	EMB-1
		Airfreight- oceanfreight	EMB-3

Inherent in our DNA

We use technology to create technology.
Our commitment to the digitization and versatility of our equipment has led to the creation of our exclusive ID PLUS system which allows the control of all ID machines through a simple Plug & Play Joystick.



INDUSTRIAS DAVID S.L.U.
C/ Médico Miguel Lucas s/n
CP: 30510, Yecla, Murcia-Spain
Tel.: +34 968 718 119
info@id-david.com

Connect with us.
[instagram.com/iddavid_official](https://www.instagram.com/iddavid_official)
twitter.com/IDdavidslu
[facebook.com/industriasdavid](https://www.facebook.com/industriasdavid)
[linkedin.com/company/id-david](https://www.linkedin.com/company/id-david)
[youtube.com/industriasdavid](https://www.youtube.com/industriasdavid)

www.id-david.com

