

V-DUAL

EN

*Multipurpose discs pruner 2
rows cutting*



SERIE

V-DUAL



Multipurpose discs pruner 2 rows cutting. Ideal for pruning 2 rows simultaneously, either on the sides or the topping. Its design is suitable for working in extensive fruit plantations, both traditional and hedges.

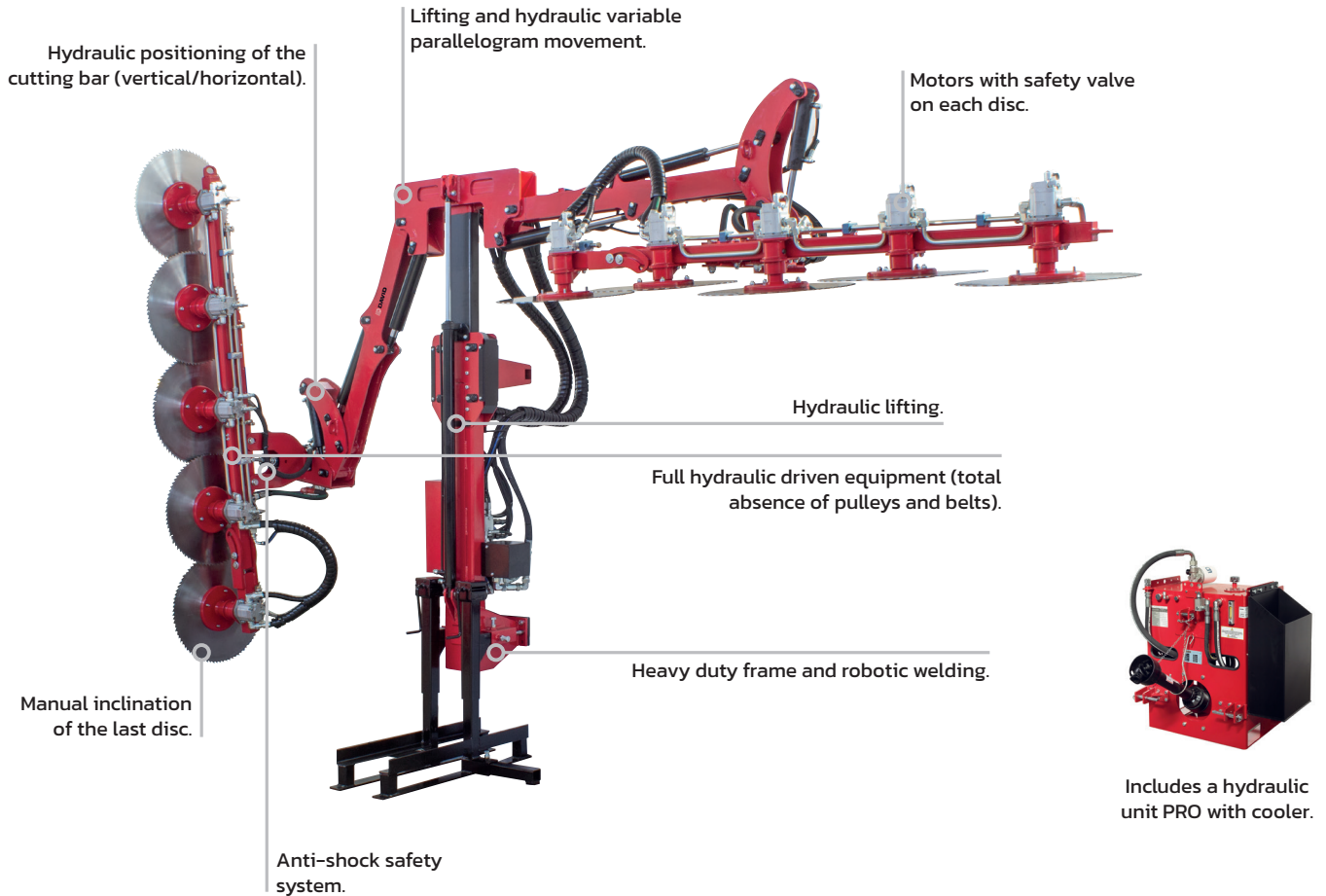

PICTURE MODEL:
V2-5D



Versatility

- Different models of discs to guarantee quality and cutting power adapted to each type and intensity of pruning.
- The ID-CONTROL joystick allows to control all the machines manufactured by ID David and equipped with the ID-PLUS or ID-MICRO technology.
- Models adjustable to any kind of plantation system.

Reliability

- Components and materials of high quality.
- Low maintenance. No lubrication in its essential parts.
- Manufacturing experience since 1983.

Exclusivity

- The first and unique range of pruners in the world equipping each disc with independent hydraulic motors since 2001.
- Hydraulic parallelogram system for a quick and easy positioning of the cutting bar.
- Electronic indication for RPM of cutting disc (optional).

Safety

- Anti-shock safety system.
- Motors with safety valve and automatic reset in case of a shut down.
- Great vision during working phase.

Effectiveness

- Electrohydraulic system optimized for extremely low power consumption.
- Correct evacuation of the remains of the pruning.
- High cutting capacity up to 20 cm.

Sustainability

- Our painting is lead-free and without toxic pigments.
- The low power required allows the use of small tractors with a lower carbon footprint.
- Sustainable consumption: Equipment designed to be up-to-date and have a long service life.

Standard Equipment

- 1 Motor + safety valve on each disc.
- Hydraulic lifting.
- Electrohydraulic independent opening of right and left cutting modules.
- Electrohydraulic independent positioning of right and left cutting modules.
- ON-OFF of the cutting modules (independent).
- Hardened steel 86 teeth-disc.
- Safety system with automatic reset.
- Includes a PRO hydraulic unit with cooler, double pump and quick couplings.
- Storage foot.
- Adaptable standard plate to tractor (frontal).
- Lateral support rods.



Remote control type



ID-PLUS

- Includes ID-CONTROL multifunction joystick.
- Includes an electronic microcontroller: allows software updates at any time.

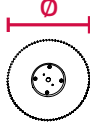
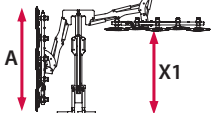
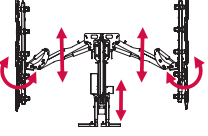

ID-MICRO

- ! NOT included the ID-CONTROL multifunction joystick.
- Only for customers who already have the ID-CONTROL multifunction joystick.
- Includes an electronic microcontroller: allows software updates at any time.

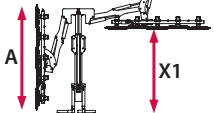
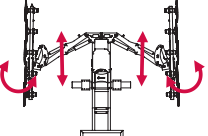

	ID-PLUS 	ID-MICRO 		
V-DUAL	REF.	REF.	N° DISCS	A (m) / X1 (m)
 <p>INDEPENDENT CUTTING, CUTTING BARS LIFTING BY PARALLELOGRAM, CUTTING BARS TILTING, LIFTING</p>	V2-5D-1	V2-5D-2	5+5 Ø600 mm	2,75 / 0,60-3,50
	V2-6D-1	V2-6D-2	6+6 Ø600 mm	3,25 / 0,60-3,50

	ID-PLUS 	ID-MICRO 		
V-DUAL	REF.	REF.	N° DISCS	A (m) / X1 (m)
<p>to be mount on the tractor loader</p>  <p>INDEPENDENT CUTTING, CUTTING BARS LIFTING BY PARALLELOGRAM, CUTTING BARS TILTING</p>	V2-PC-5D-1	V2-PC-5D-2	5+5 Ø600 mm	2,75 / According to the front loader model
	V2-PC-6D-1	V2-PC-6D-2	6+6 Ø600 mm	3,25 / According to the front loader model

Technical details

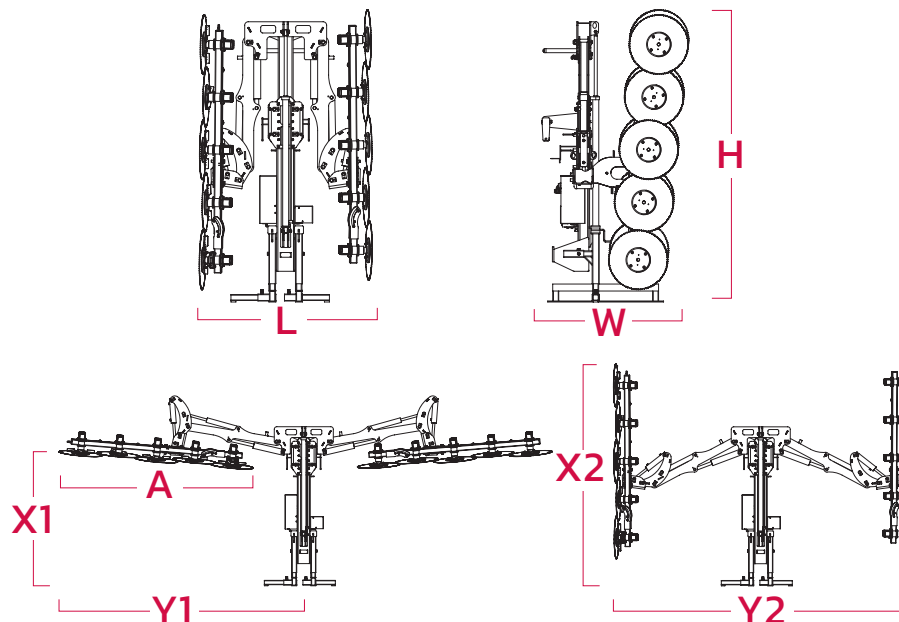
	REF.	X1	Y1 (Max)	X2 (Max)	Y2	A			L	W	H
		m	m	m	m	m	kg	HP	m	m	m
V-DUAL	V2-5D	0,60-3,50	3,35	5,50	1,70-4,20	2,75	890	90	1,70	1,50	2,80
	V2-6D	0,60-3,50	3,85	6,00	1,70-4,20	3,25	950	100	1,70	1,50	3,30





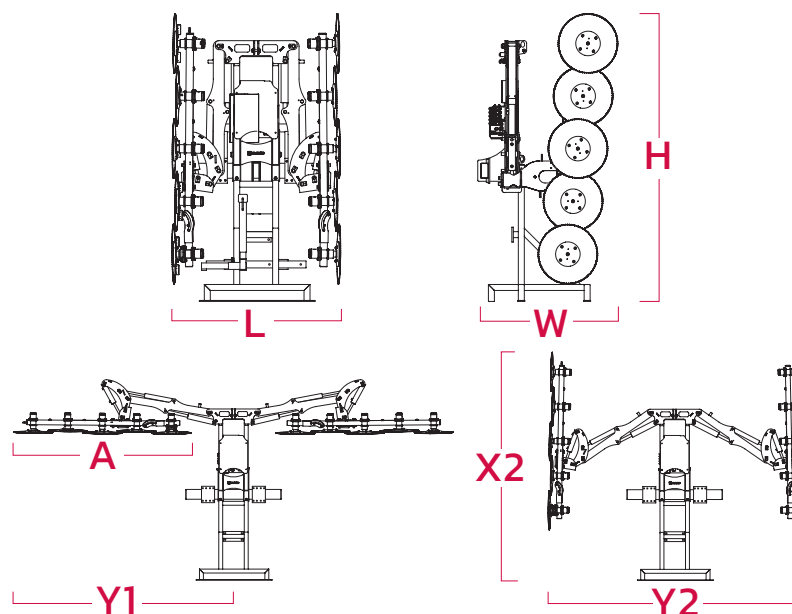









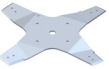

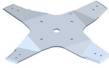
V-DUAL	REF.	X1	Y1 (Max)	X2 (Max)	Y2	A			L	W	H
		m	m	m	m	m	kg	HP	m	m	m
TO BE MOUNT ON THE TRACTOR LOADER	V2-PC-5D	-	3,35	4,75	1,70-4,20	2,75	960	100	1,70	1,50	2,90
	V2-PC-6D	-	3,85	5,25	1,70-4,20	3,25	1020	110	1,70	1,50	3,40



Tractor mounting



Prepruner Accessories and Options

	DESCRIPTION	OBSERVATIONS	REF.
	Cutting disc type HOZ: specific for almond trees		 D-Z2H-R
	Knife discs for green branches with suction system	Right	 D-Z4-D
	Knife discs for green branches with suction system	Left for equipments with MTR-5 MTR-6	 D-Z4-I
	Hardened steel 150 teeth-disc	Thin branches or fibrous materials	 D-Z150
	Hardened steel 100 teeth-disc		 D-Z100
	Hardened steel 86 teeth-disc	Standard included	 D-Z86
	DAVISC 40 notched-Disc		 DA-Z40
	RPM electronic counter of cutting disc		IE-RPM

	DESCRIPTION	OBSERVATIONS		REF.
	Quick hitch to front loader	Indicate frontloader brand and model		ER-PC
	Plate for front tractor coupling	It will be supplied only if the corresponding form has been correctly filled out		PA-F
	Super-reinforced 3-point linkage	Front 3P or reversible tractor		T2P-11
	Sharpening tool			M-A
	Sharpener disc replacement	For HSS disc and DAVISC disc		D-AA
	Disinfectant application kit	For 5 + 5 disc equipment	Includes 200L stainless steel tank and electric pump	K-AD-55
		For 6 + 6 disc equipment		K-AD-66
	INOX 200 L additional tank for disinfectant kit	Possibility of adapting up to 2 units		KDD20
	Protective screen of the cutting bar	for 5+5 discs cutting bar	Unit	PAP-10D6
		For 6+6 discs cutting bar	Unit	PAP-12D6
	*Recommended with disinfection kit			
	Disc protective screen			PD-D6
	Kit Reversibles motors	Only for V-hedge trees		MTR-10
				MTR-12
	Storage Wheel Kit	For hydraulic power plant		KRCH
	Packaging	Basic		EMB-1
		Airfreight- oceanfreight		EMB-3

Inherent in our DNA

We use technology to create technology.
Our commitment to the digitization and versatility of our equipment has led to the creation of our exclusive ID PLUS system which allows the control of all ID machines through a simple Plug & Play Joystick.



INDUSTRIAS DAVID S.L.U.
C/ Médico Miguel Lucas s/n
CP: 30510, Yecla, Murcia-Spain
Tel.: +34 968 718 119
info@id-david.com

Connect with us.
[instagram.com/iddavid_official](https://www.instagram.com/iddavid_official)
twitter.com/IDdavidslu
[facebook.com/industriasdavid](https://www.facebook.com/industriasdavid)
[linkedin.com/company/id-david](https://www.linkedin.com/company/id-david)
[youtube.com/industriasdavid](https://www.youtube.com/industriasdavid)

www.id-david.com

