

ALH

EN

*Front berm sweeper for pruning
remains in vines and fruit trees*

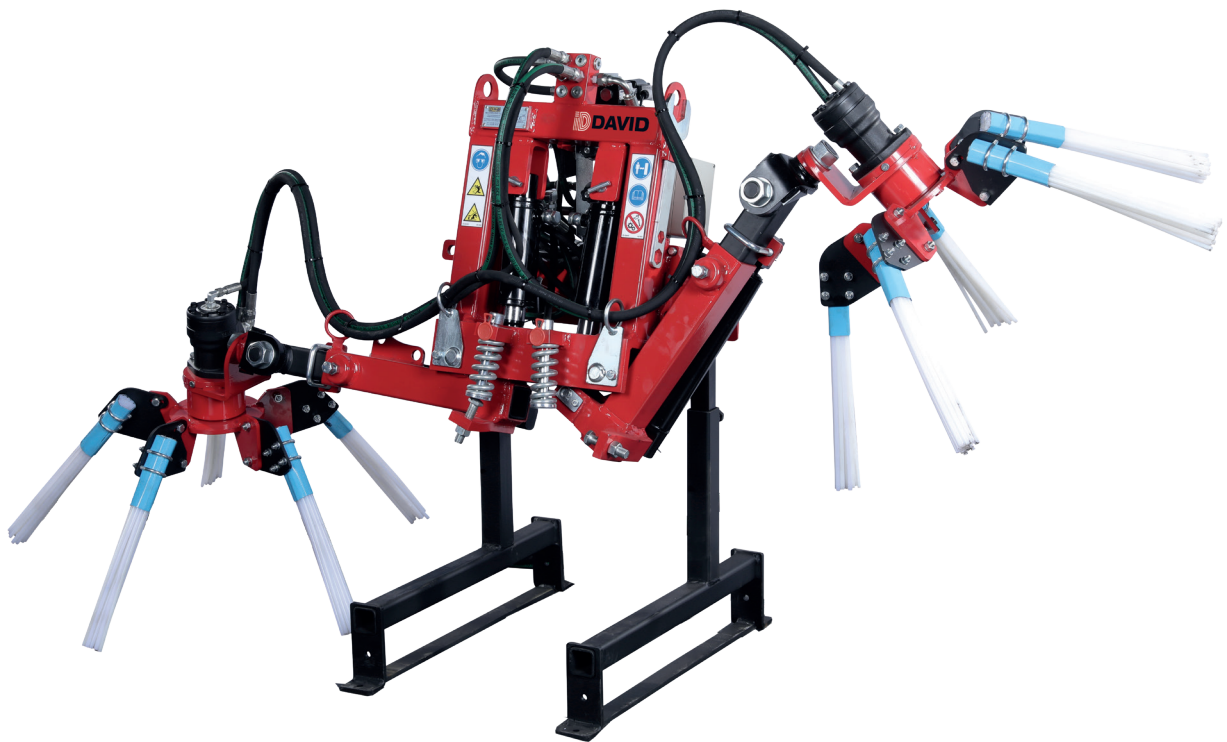

VITI



SETO



ARBO



DAVID
SMART FARMING SOLUTIONS

SERIE

ALH



Front berm sweeper for pruning remains in vines and fruit trees, designed to move and alline the branches resulting from pruning in a compact line to facilitate collection or mulching simultaneously with a single pass of the tractor.

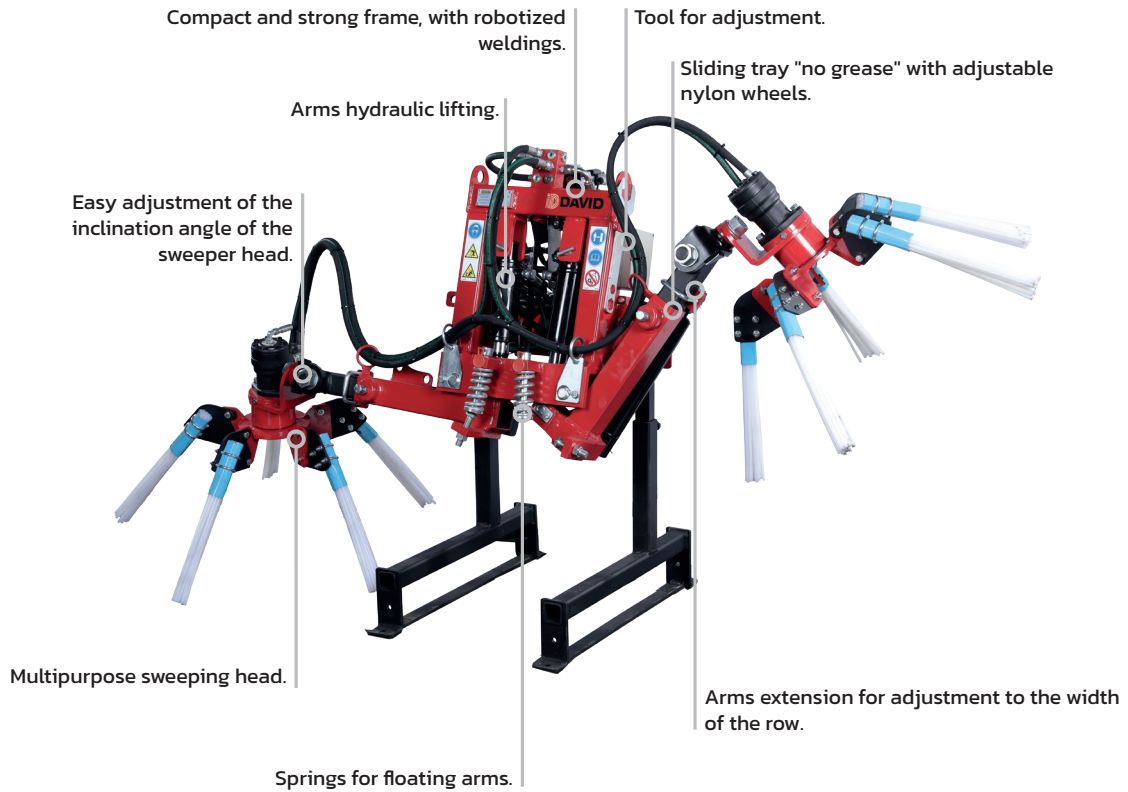

PICTURE MODEL:
ALH-S-N

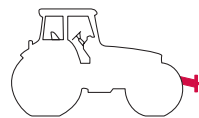

Versatility

- The ID-CONTROL joystick allows to control all the machines manufactured by ID David and equipped with the ID-PLUS or ID-MICRO technology.
- It is possible to expand anytime the equipment functionality by exchanging the heads.

Exclusivity

- Multifunction frame: berm sweeper + herbicide applicator + rotary brush + sweeper.
- The hydraulic suspension of the sweeper heads allows a perfect adaptation to the ground and extends the useful life of the brushes.

Effectiveness

- Diameter and size of the brushes can be modified quickly and easily.
- Clean soil improves plant health, reduces the risk of illness and the use of phytosanitary products.

Reliability

- Components and materials of high quality.
- Low maintenance.
- Manufacturing experience since 1990.

Safety

- The strong frame as well as light and compact allows a perfect vision and occupies a minimum space by facilitating the turning in tight spaces.
- Sweeper heads fitted with bearings to get total protection of the motors against shocks.

Sustainability

- The low power required allows the use of small tractors with a lower carbon footprint.
- Sustainable consumption: Equipment designed to be up-to-date and have a long service life.
- Aligning and mowing pruned branches improves soil quality by providing nutrients and reduce the emission of CO2 that occurs during combustion.

Standard Equipment

- Sliding tray "no grease" with adjustable nylon wheels.
- Flow regulator of the sweeping turns.
- Tool for adjustment.
- Hydraulic lifting with single effect (floating system).
- Hydraulic extensions.
- Nylon blades or rubber brushes.
- Storage foot.
- Adaptable standard plate to tractor (frontal).

Remote control type

ID-PLUS

- Includes ID-CONTROL multifunction joystick.
- Includes an electronic microcontroller: allows software updates at any time.
- Up to 4 additional electro-hydraulic functions.
- Includes a modular electro-hydraulic system: it allows to increase the number of electro-hydraulic functions.

ID-MICRO









- ! NOT included the ID-CONTROL multifunction joystick.
- Only for customers who already have the ID-CONTROL multifunction joystick.
- Includes an electronic microcontroller: allows software updates at any time.
- Up to 4 additional electro-hydraulic functions.
- Includes a modular electro-hydraulic system: it allows to increase the number of electro-hydraulic functions.

ID-BASIC

- Includes an electric control box.
- Hydraulic connection to the tractor by 2 hoses.
- ! NOT allowed any updates of electro-hydraulic functions.
- ! NOT allowed extra hydraulic functions.
- ! NOT included the electronic microcontroller.

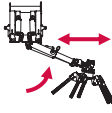
DIRECT TO TRACTOR

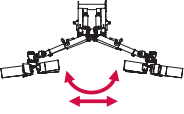
- Includes a pipe with 1/2 male plugs for the hydraulic lift.
- Includes a pair of hoses with 1/2 male plugs for hydraulic extension.
- Includes a pair of hoses with 1/2 male connectors for ON/OFF.
- ! NOT included the ID-CONTROL multifunction joystick.
- ! NOT included the electronic microcontroller.
- ! NOT allowed extra hydraulic functions.

			 ID-PLUS	 ID-MICRO	 ID-BASIC	 DIRECT TO TRACTOR
ALH	HEAD	(m)	REF.	REF.	REF.	REF.
HALF ROW SWEEPER  MOTOR, LIFTING, EXTENSION		≥ 4	ALH-D-P-1	ALH-D-P-2	ALH-D-P-3	ALH-D-P-5
		≥ 4	ALH-D-N-1	ALH-D-N-2	ALH-D-N-3	ALH-D-N-5
DOUBLE ROWS SWEEPER  MOTOR, LIFTING, EXTENSION		1,70-2,30	ALH-XS-P-1	ALH-XS-P-2	ALH-XS-P-3	ALH-XS-P-5
		2,40-3,05	ALH-S-P-1	ALH-S-P-2	ALH-S-P-3	ALH-S-P-5
		2,80-3,45	ALH-SA-P-1	ALH-SA-P-2	ALH-SA-P-3	ALH-SA-P-5
		2,95-4,05	ALH-M-P-1	ALH-M-P-2	ALH-M-P-3	ALH-M-P-5
		3,40-4,50	ALH-L-P-1	ALH-L-P-2	ALH-L-P-3	ALH-L-P-5
		1,70-2,30	ALH-XS-N-1	ALH-XS-N-2	ALH-XS-N-3	ALH-XS-N-5
		2,20-2,60	ALH-S-N-1	ALH-S-N-2	ALH-S-N-3	ALH-S-N-5
		2,50-2,90	ALH-SA-N-1	ALH-SA-N-2	ALH-SA-N-3	ALH-SA-N-5
		2,60-3,50	ALH-M-N-1	ALH-M-N-2	ALH-M-N-3	ALH-M-N-5
		3,05-3,95	ALH-L-N-1	ALH-L-N-2	ALH-L-N-3	ALH-L-N-5

Technical details

ALH		A	B	C				L	W	H
REF.		m	m	mm	kg	HP	m	m	m	
SINGLE	ALH-D-P	1,90-2,35	1,30	Ø300	220	40	2,30	1,00	1,30	
	ALH-D-N	1,90-2,05 (*)	1,10	Ø300	220	40	2,20	1,00	1,30	
DOUBLE	ALH-XS-P	1,70-2,10	0,85	Ø100	230	40	1,70	1,00	1,30	
	ALH-S-P	2,40-2,85	1,00	Ø200	240	40	1,70	1,00	1,50	
	ALH-SA-P	2,80-3,25	1,00	Ø200	245	40	1,90	1,00	1,50	
	ALH-M-P	2,95-3,85	1,20	Ø200	250	40	2,20	1,00	1,80	
	ALH-L-P	3,40-4,30	1,30	Ø300	260	40	2,20	1,00	2,00	
	ALH-XS-N	1,70-2,10 (*)	0,85	Ø100	230	40	1,70	1,00	1,30	
	ALH-S-N	2,20-2,40 (*)	1,00	Ø200	240	40	1,70	1,00	1,50	
	ALH-SA-N	2,50-2,75 (*)	1,00	Ø200	245	40	1,90	1,00	1,50	
	ALH-M-N	2,60-3,30 (*)	1,00	Ø200	250	40	2,20	1,00	1,50	
	ALH-L-N	3,05-3,75 (*)	1,10	Ø300	260	40	2,20	1,00	2,00	

(*) ±20 cms with manual adjustment.

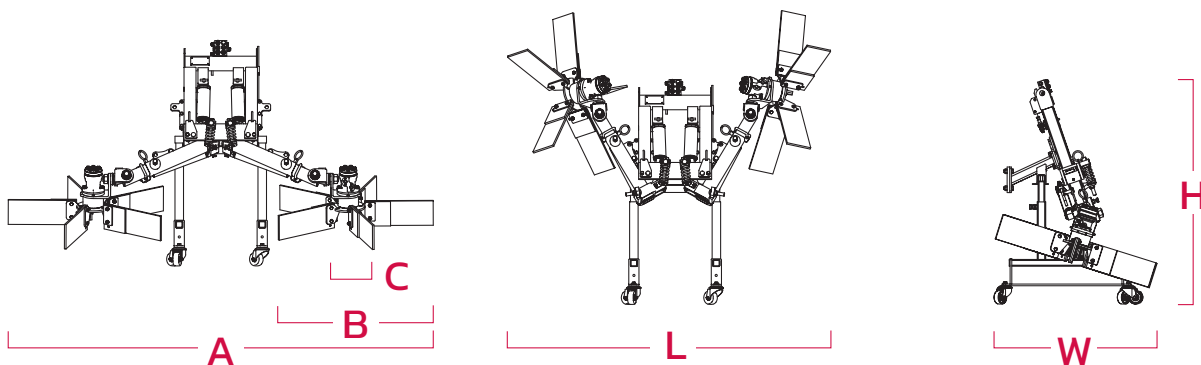



Tractor mounting

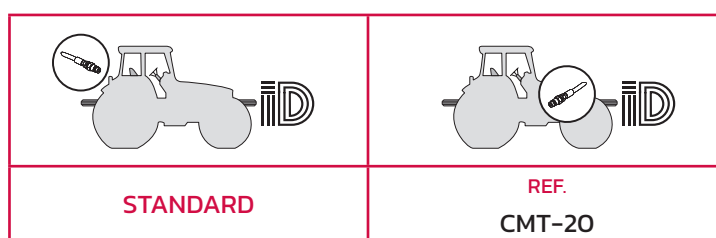

Tractor connection and assembling

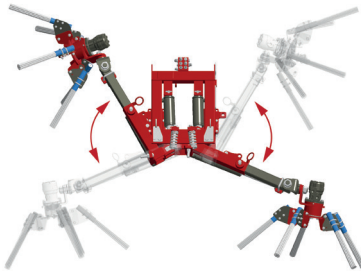

Kit PRO - option

📷	OBSERVATIONS	REF.
	Allows the tool arms to be lifted individually or simultaneously.	ID-PLUS and ID-MICRO EIB-1
	Direct to tractor	EIB-2
		

Sweeper Accessories and Options

📷	DESCRIPTION	OBSERVATIONS	REF.
	Hydraulic power unit 60 L to 3 Point linkage	Pump 35 liters	C12
	Standard oil cooler	Adaptable to 60 lt hydraulic power plant	A15-60
	Storage Wheel Kit		KRA
	Herbicide application head with 2 nozzles	Right	for XS CHR1-D
			for S / M / L CHR2-D
		Pair	for XS CHR1-P
	Width of application 55 cm		for S / M / L CHR2-P
	Herbicide application head with 3 nozzles	Right	CHR3-D
			Not available for XS
		Pair	CHR3-P
	250 mm right rotary brush + slide + string spool	Additional head	for XS C-DBR-1-D
			for S / M / L C-DBR-3-D
		Replace berm sweeper head	for XS Includes arm C-DBR-2-D
	*Advisable the C12 power unit and to note that it works only in vineyards with at least 40 cm stump free.		for S / M / L C-DBR-4-D
	250 mm pair of rotary brush + slide + string spool	Additional head	for XS Includes arm C-DBR-1-P
			for S / M / L C-DBR-3-P
		Replace berm sweeper head	for XS Includes arm C-DBR-2-P
	*Advisable the C12 power unit and to note that it works only in vineyards with at least 40 cm stump free.		for S / M / L C-DBR-4-P

	DESCRIPTION	OBSERVATIONS	REF.
	Nylon string blue spool	for brush head	90 m BHN-01
	Nylon string black spool	for mower head	58 m BHN-02
	Supports and nylon whips	1 berm sweeper head	A-EN-D
		2 berm sweeper head	A-EN-P
	Nylon brushes	1 berm sweeper head	EN-D
		2 berm sweeper head	EN-P
	Rubber blades supports	1 berm sweeper head	APG-D
		2 berm sweeper head	APG-P
	Rubber brush 400 mm special for vineyard	1 berm sweeper head	P-40V-D
		2 berm sweeper head	P-40V-P
	Reversible Rubber brush 400 x 150 mm	1 berm sweeper head	P-4015-D
		2 berm sweeper head	P-4015-P
	Reversible Rubber brush 500 x 200 mm	1 berm sweeper head	P-5020-D
		2 berm sweeper head	P-5020-P
	Plate for front tractor coupling	It will be supplied only if the corresponding form has been correctly filled out	
	3 Points linkage	Front 3P or reversible tractor	T3P-16
	Kit longer extension	Increases working width of 20 cm	for 1 arm KP20-D
			for 2 arms KP20-P
	Control for simultaneous use of mower with hydraulic pick-up + berm sweeper	for ID-PLUS / ID-MICRO	MST-01
		for ID-BASIC	MST-03
	Packaging	Basic	EMB-1
		Airfreight- oceanfreight	EMB-3

The value of ideas

Experience, technology, know-how and design are the fundamentals to achieving our goal: the support and full satisfaction of the farmer. Being excellent in everything we do is our guiding light.



INDUSTRIAS DAVID S.L.U.
C/ Médico Miguel Lucas s/n
CP: 30510, Yecla, Murcia-Spain
Tel.: +34 968 718 119
info@id-david.com

Connect with us.
[instagram.com/iddavid_official](https://www.instagram.com/iddavid_official)
twitter.com/IDdavidslu
[facebook.com/industriasdavid](https://www.facebook.com/industriasdavid)
[linkedin.com/company/id-david](https://www.linkedin.com/company/id-david)
[youtube.com/industriasdavid](https://www.youtube.com/industriasdavid)

www.id-david.com

