

TD-SO

EN

Mower with double hydraulic pick-up



SETO



ARBO



DAVID
SMART FARMING SOLUTIONS

SERIE

TD-50



Mower with double hydraulic pick-up for mulching pruning remains in orchards, almond and olive trees up to 15 cm.

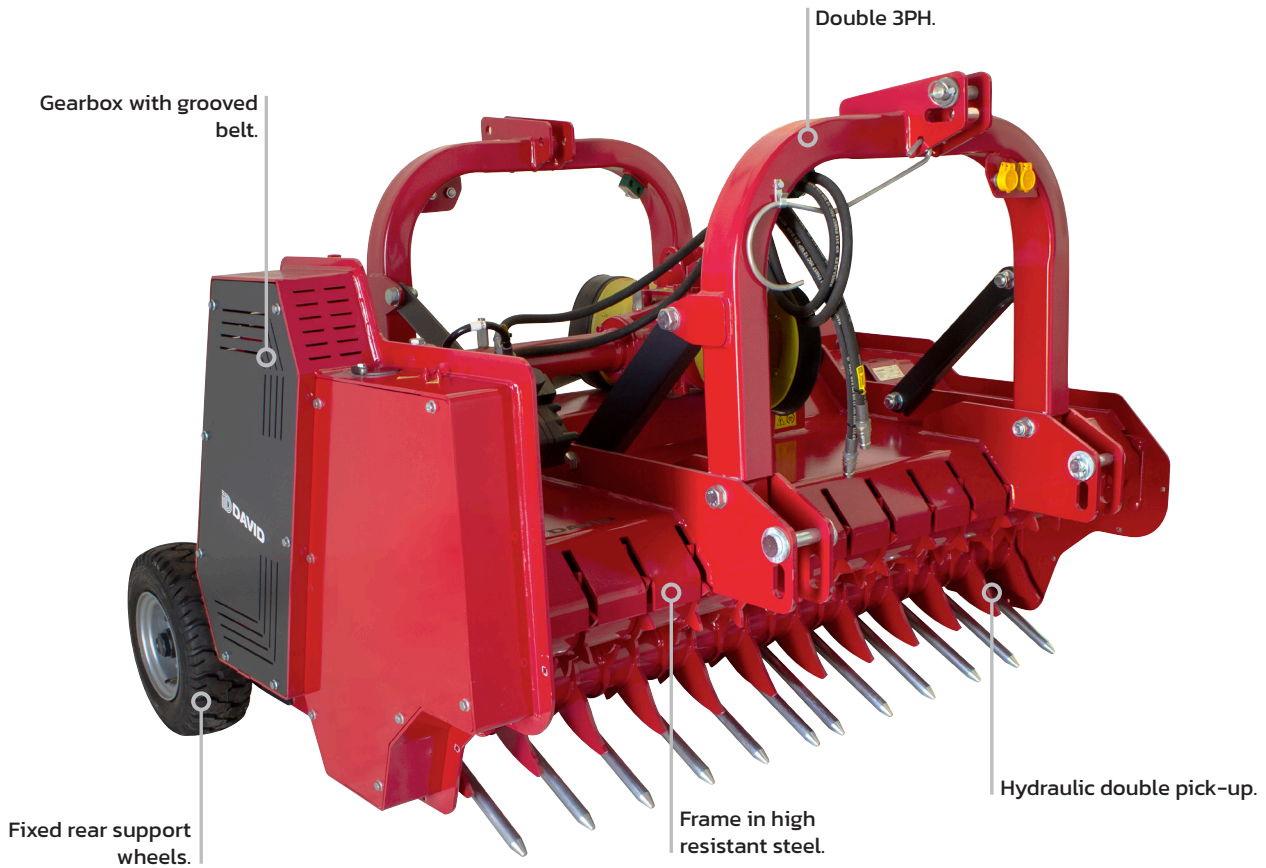

PICTURE MODEL:
TD-SO-200 + TGDR-5 + PLS5-20



Versatility

- Models adjustable to any kind of plantation system.
- Possibility of simultaneous use with sweeper.
- By changing the position of the 3P hitch and the wheels it is possible to work in reverse when there is a large accumulation of branches.

Reliability

- We use the latest generation materials to avoid cracks and crevices and able to withstand at highest load limit.
- Exclusive design of the "pick-up" assembly which prevents the entry of stones into the mowers chamber.
- Features a paddle cooling system integrated into the pulley to ventilate and remove heat generated by belt friction.

Exclusivity

- Equipment built with high elastic limit steels and anti-wear qualities.
- Includes DS system for quick change of gearbox input speed from 540 rpm to 1000 rpm by reversing the pulleys.

Safety

- All models are designed for simple and intuitive operations.
- Lubrication points protected from shocks.
- Gearbox with internal freewheel.

Effectiveness





- High working speed.
- All models are fitted with fixed wheels for perfect ground adaptation and easy maneuvering.
- Rear opening for easy maintenance.

Sustainability

- Mowing pruned branches improves soil quality by providing nutrients and reduce the emission of CO2 that occurs during combustion.

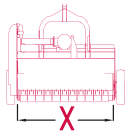
Standard Equipment

- Transmission driven by belts (XPB).
- Double 3PH.
- High strength steel chassis.
- Double hydraulic pick-up.
- Gearbox with free wheel (1³/₄ - Z6).
- Rotor Ø412 with oscillating hammers and Ø27 mm screws.
- Rear fixed support wheels.
- Mulching system with sieve.
- Transmission at 540 rpm (optional 1000 rpm by inversion of pulleys with DS system).
- PTO Bondioli G9.

			Ø CUT ROTOR			HAMMER 
TD-SO	m	n°	mm	kg	HP	REF.
	1,50	14	412	1235	70-120	TD-SO-150
"DOBLE PICK-UP" MOWER	1,80	16	412	1360	80-120	TD-SO-180
	2,00	18	412	1445	90-120	TD-SO-200



Technical details

			L	W	H
TD-SO	REF.	mm	m	m	m
"DOBLE PICK-UP" MOWER	TD-SO-150	750-750	1,74	1,74	1,32
	TD-SO-180	900-900	2,04	1,74	1,32
	TD-SO-200	1.000-1.000	2,24	1,74	1,32

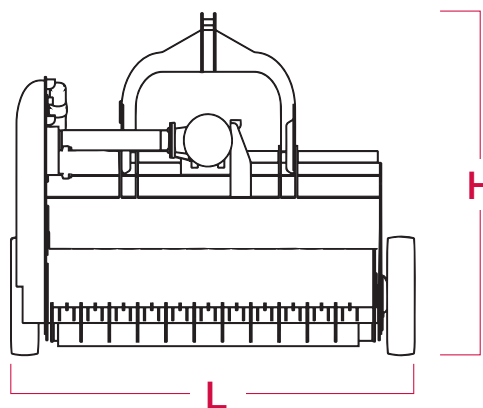
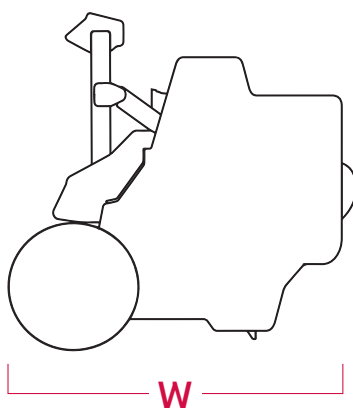

Mower Accessories and Options

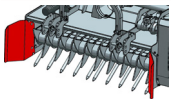
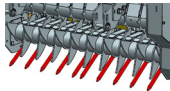
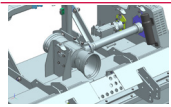
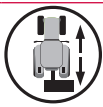
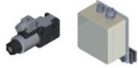
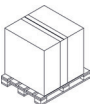
	DESCRIPTION	OBSERVATIONS	REF.
	Lateral flaps kit		TFL5
	Branch lifter kit	for TD-SO-150	PLS5-15
		for TD-SO-180	PLS5-18
		for TD-SO-200	PLS5-20
	Double free wheel and double head Group		TGDR-5
	Control for simultaneous use of mower with hydraulic pick-up + berm sweeper		MST-03
	Packaging	Basic	EMB-1
		Airfreight- oceanfreight	EMB-2

The value of ideas

Experience, technology, know-how and design are the fundamentals to achieving our goal: the support and full satisfaction of the farmer. Being excellent in everything we do is our guiding light.



INDUSTRIAS DAVID S.L.U.
C/ Médico Miguel Lucas s/n
CP: 30510, Yecla, Murcia-Spain
Tel.: +34 968 718 119
info@id-david.com

Connect with us.
[instagram.com/iddavid_official](https://www.instagram.com/iddavid_official)
twitter.com/IDdavidslu
[facebook.com/industriasdavid](https://www.facebook.com/industriasdavid)
[linkedin.com/company/id-david](https://www.linkedin.com/company/id-david)
[youtube.com/industriasdavid](https://www.youtube.com/industriasdavid)

www.id-david.com

