

PRUNEX

EN

Tunnel precision pruner



PRUNEX



Tunnel precision pruner. Pruning equipment designed for precision cutting in olives and almonds trees, berries, blueberries and vineyards on trellis system with posts that do not exceed the cordon line, drastically reducing or even entirely avoiding the manual operations.

NEW

CAN

ACS

IRON CAST

Powered by **SKF**

Maintenance free hub.

Pendular suspension through double spring system.

Full hydraulic driven equipment (total absence of pulleys and belts).

Hydraulic adjustment of the horizontal cutting height.

Manual adjustment of both angle of incidence and tilting of the cutting bars.

Hydraulic lifting.

Self-lubricating sliding tray with adjustable nylon rollers.

8 cm

3 cm

Motors with safety valve on each disc.

Special steel knives with 4 teeth.

Alternative cutting bar with reinforced crankshaft.

Includes a PRO hydraulic unit.

Picture model: PR-X10

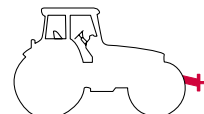

Versatility

- The ID-CONTROL joystick allows to control all the machines manufactured by ID David and equipped with the ID-PLUS or ID-MICRO technology.
- Models adjustable to any kind of plantation system.



Exclusivity

- The first and unique range of pruners in the world equipping each disc with independent hydraulic motors since 2001.



Effectiveness

- Electrohydraulic system optimized for extremely low power consumption.
- Cutting elements supported by years of experience in the market.
- Correct evacuation of the remains of the pruning.



Reliability

- Components and materials of high quality.
- Low maintenance. No lubrication in its essential parts.
- Motors with safety valve and automatic reset in case of a shut down.



Safety

- Maintains a constant verticality of the cutting head by the exclusive pendular suspension system that absorbing the ground irregularities.



Sustainability

- Our painting is lead-free and without toxic pigments.
- The low power required allows the use of small tractors with a lower carbon footprint.
- Sustainable consumption: Equipment designed to be up-to-date and have a long service life.

Standard Equipment

- Anti-shock security fuse.
- Hydraulic lifting.
- Hydraulic width adjusting.
- Hydraulic adjustment between modules of vertical cut.
- Pendular suspension by means of a double spring.
- Storage foot.
- Includes a PRO hydraulic unit with cooler and quick couplings.
- Adaptable standard plate to tractor (frontal).
- Lateral support chains.
- Cutting discs Ø600 x 86 teeth.
- Alternative cutting bar with reinforced crankshaft.

Remote control type

ID-PLUS

- It includes ID-CONTROL multifunction joystick.
- Includes an electronic microcontroller: allows software updates at any time.

ID-MICRO

- ! Not included the ID-CONTROL multifunction joystick.
- Only for customers who already have the ID-CONTROL multifunction joystick.
- Includes an electronic microcontroller: allows software updates at any time.

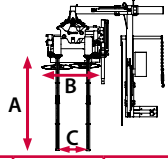
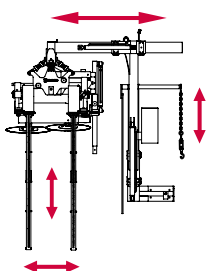

PRUNEX	ID-PLUS	ID-MICRO	Ø			
	REF.	REF.	N° DISCS	A (m)	B (m)	C (m)
 <p>CUTTING, OPENING, LIFTING, EXTENSION, HORIZONTAL CUTTING BAR LIFTING</p>	PR-X10-1	PR-X10-2	2	1,00	1,10	300-940
	PR-X17-1	PR-X17-2	Ø600	1,65	1,10	300-940
	PR-X20-1	PR-X20-2		2,00	1,10	300-940

PRUNEX

Pruning, pruning and
leaf stripping



Technical details

PRUNEX		X	A	B	C	Y*			L	W	H
REF.		m	m	m	m	m	kg	HP	m	m	m
PRECISION PRUNER FOR VINEYARD	PR-X10	1,30-2,45	1,00	1,10	0,30-0,94	1,33-1,83	750	70	2,35	1,31	3,00
	PR-X17	1,30-2,45	1,65	1,10	0,30-0,94	1,33-1,83	770	70	2,35	1,31	3,00
	PR-X20	1,65-2,45	2,00	1,10	0,30-0,94	1,33-1,83	790	70	2,35	1,31	3,00

(*) $\pm 0,125$ m.

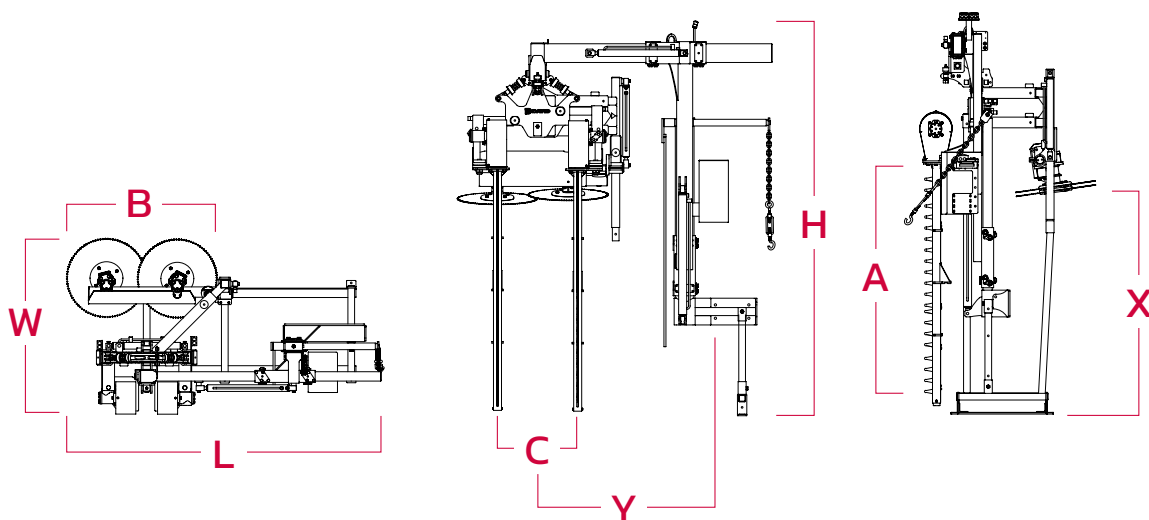



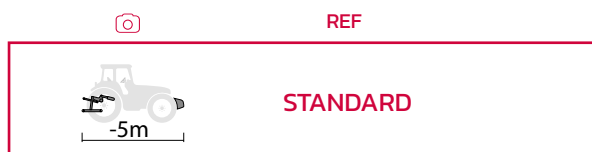







Tractor mounting

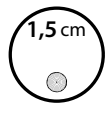

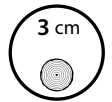
Connectivity and telemetry Accessories and Options

	DESCRIPTION	OBSERVATIONS	REF.
	Visualization and telematics monitoring pack	*Only available for new machine with ID-PLUS PRO hydraulic power pack + oil cooler required	FPRO-05

Pruner Accessories and Options

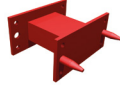
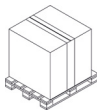
	DESCRIPTION	OBSERVATIONS	REF.
	Bottom cutting bar for pruning in vineyards with a simple cordon	Electric cabine	M-PO-5-D
	Knife discs for green branches: ideal for almond trees	Left	 D-Z3-I
	Hardened steel 150 teeth-disc	Thin branches or fibrous materials	 D-Z150
	Hardened steel 100 teeth-disc		 D-Z100
	Hardened steel 86 teeth-disc	Standard included	 D-Z86
	Counterweight box	Can be coupled to a hydraulic power plant of 80 or 150 lt	CPM-01
	3 Points linkage	Front 3P or reversible tractor	T3P-15
	Plate for front tractor coupling	It will be supplied only if the corresponding form has been correctly filled out	PA-F
	Packaging	Basic	EMB-1
		Airfreight- oceanfreight	EMB-2

Our 3-keys Ideology

Organizational culture

We focused on Lean Manufacturing philosophy to improve operations management, products and workspaces

The Agile Methodology provides us a way to develop better projects in a faster manner, involving and organizing staff to operate as a whole

Design is our attitude and Design Thinking is the tool to face challenges and solve problems, designing products and services focused on users, involving them in the creative process

Mindset
ID



INDUSTRIAS DAVID S.L.U.
C/ Médico Miguel Lucas s/n
CP: 30510, Yecla, Murcia-Spain
Tel.: +34 968 718 119
info@id-david.com

Connect with us.
[instagram.com/iddavid_official](https://www.instagram.com/iddavid_official)
twitter.com/IDdavidslu
[facebook.com/industriasdavid](https://www.facebook.com/industriasdavid)
[linkedin.com/company/id-david](https://www.linkedin.com/company/id-david)
[youtube.com/industriasdavid](https://www.youtube.com/industriasdavid)

www.id-david.com

