

PV-VIEW-R

EN

*Trimmer for vineyards and hedge
crops to keep canopy under
control*

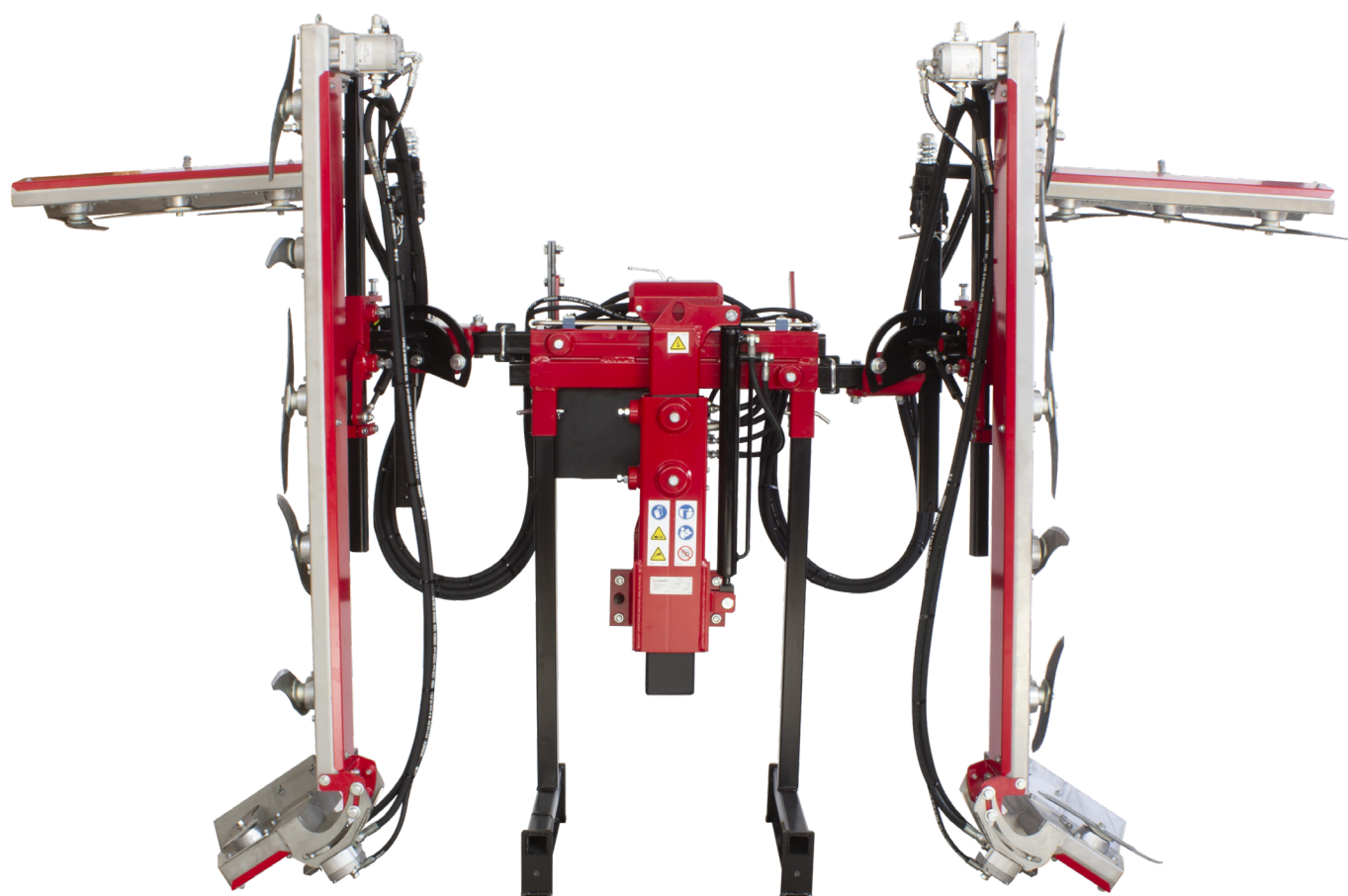

 **DAVID**

PV-VIEW-R



Trimmer for vineyards and hedge crops to keep canopy under control. High working speeds, clean cut, low maintenance and excellent view from the cab. Available 4 cutter bars and 6 electro-hydraulic functions.

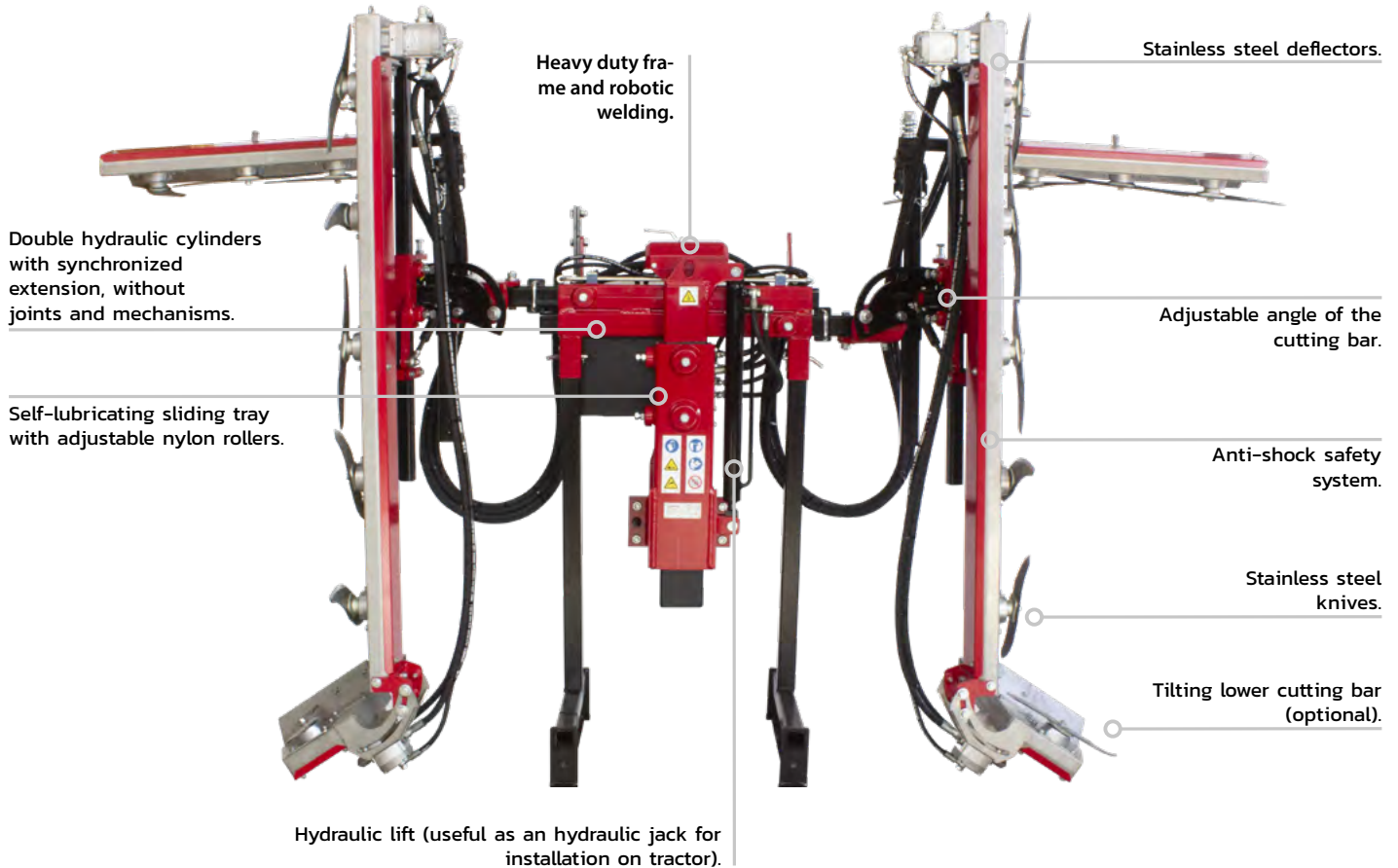

PICTURE MODEL:
PV-R-1710-M

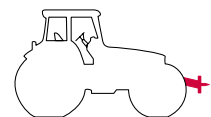
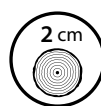

Versatility

- The ID-CONTROL joystick allows to control all the machines manufactured by ID David and equipped with the ID-PLUS or ID-MICRO technology.
- Models adjustable to any kind of plantation system.

Exclusivity

- Exclusive blade design that guarantees a perfect cut.

Effectiveness

- It allows a working speed up to 15 km/h.
- Electrohydraulic system optimized for extremely low power consumption.

Reliability

- Components and materials of high quality.
- Low maintenance (no needs of lubrication in its key parts).
- Cutting elements supported by years of experience in the market.
- Manufacturing experience since 1975.

Safety

- Power transmission to the blades through maintenance-free V-belts.

Sustainability

- An optimal cut improves ventilation and plant health by reducing the use of phytosanitary products.
- The low power required allows the use of small tractors with a lower carbon footprint.
- Sustainable consumption: Equipment designed to be up-to-date and have a long service life.

Standard Equipment

- Anti-shock safety system.
- Sliding tray "no grease" with adjustable nylon wheels.
- Manual adjustment of the angle of incidence.
- Hydraulic lifting.
- Double hydraulic cylinder of synchronized extension.
- Manual cutting bar inclination.
- Reciprocating cutting bars with excentric crankshaft.
- Storage foot.
- Adaptable standard plate to tractor (frontal).
- Lateral support rods.

Remote control type

ID-PLUS

- It includes ID-CONTROL multifunction joystick.
- Includes an electronic microcontroller: allows software updates at any time.
- Includes a modular electro-hydraulic system: it allows to increase the number of electro-hydraulic functions.

ID-MICRO



- ! Not included the ID-CONTROL multifunction joystick.
- Only for customers who already have the ID-CONTROL multifunction joystick.
- Includes an electronic microcontroller: allows software updates at any time.
- Includes a modular electro-hydraulic system: it allows to increase the number of electro-hydraulic functions.

ID-BASIC



- Includes an electric control box.
- Hydraulic connection to the tractor by 2 hoses.
- ! Not allowed any updates of electro-hydraulic functions.
- ! Not allowed extra hydraulic functions.
- ! Not included the electronic microcontroller.

DIRECT TO TRACTOR

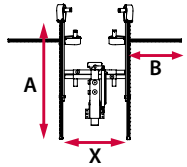
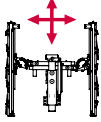
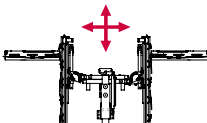
- Includes a pair of hoses with 1/2 male plugs for hydraulic lifting.
- Includes a pair of hoses with 1/2 male plugs for hydraulic extension.
- Includes a pair of hoses with 1/2 male and 3/4 female connectors for ON / OFF.
- ! Not included the ID-CONTROL multifunction joystick.
- ! Not included the electronic microcontroller.
- ! Not allowed extra hydraulic functions.

	ID-PLUS 	ID-MICRO 	ID-BASIC 			
PV-VIEW-R	REF.	REF.	REF.	X (m)	A (m)	B (m)
CANE TRIMMER VERTICAL BARS  CUT, LIFT, EXTENSION	PV-R-17-S-1	PV-R-17-S-2	PV-R-17-S-3	1,30-2,30	1,70	-
	PV-R-17-M-1	PV-R-17-M-2	PV-R-17-M-3	1,70-2,70	1,70	-
	PV-R-17-L-1	PV-R-17-L-2	PV-R-17-L-3	2,30-3,70	1,70	-
CANE TRIMMER VERTICAL AND HORIZONTAL BARS  CUT, LIFT, EXTENSION	PV-R-1710-S-1	PV-R-1710-S-2	PV-R-1710-S-3	1,30-2,30	1,70	0,90
	PV-R-1710-M-1	PV-R-1710-M-2	PV-R-1710-M-3	1,70-2,70	1,70	0,90
	PV-R-1710-L-1	PV-R-1710-L-2	PV-R-1710-L-3	2,30-3,70	1,70	0,90

Technical details

PV-VIEW-R		REF.	X	A	B			L	W	H
			m	m	m	kg	HP	m	m	m
CANE TRIMMER VERTICAL BARS	PV-R-17-S		1,30-2,30	1,70	-	270	40	1,30	1,00	2,10
	PV-R-17-M		1,70-2,70	1,70	-	290	40	1,70	1,00	2,10
	PV-R-17-L		2,30-3,70	1,70	-	330	50	2,30	1,00	2,10
CANE TRIMMER VERTICAL AND HORIZONTAL BARS	PV-R-1710-S		1,30-2,30	1,70	0,90	350	50	1,50	1,00	2,10
	PV-R-1710-M		1,70-2,70	1,70	0,90	370	50	1,90	1,00	2,10
	PV-R-1710-L		2,30-3,70	1,70	0,90	400	50	2,50	1,00	2,10

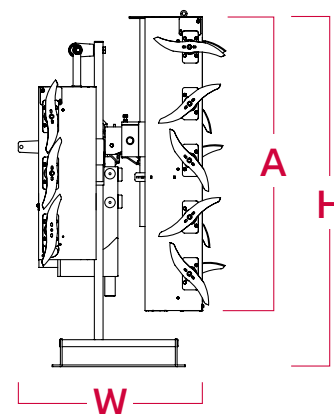
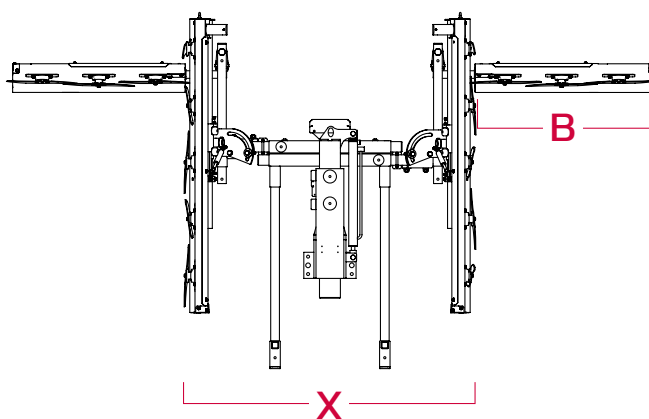
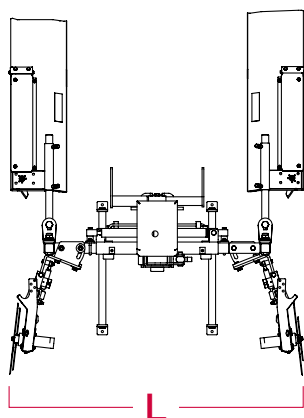

Tractor mounting

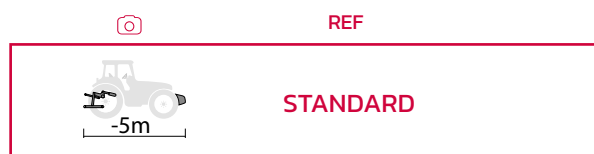

Tractor connection and assembling

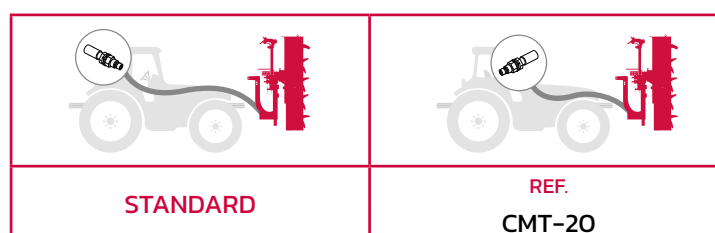

* 3PH and tractor assembly plate not included.

Basic kit to be adapted to new equipments - option

Recommended kit to use on slopes - option



OBSERVATIONS

REF.



Simultaneous vertical and horizontal tilting bars for using on hills.

available for ID-PLUS and ID-MICRO

POR-1



Simultaneous hydraulic tilting of vertical bars and horizontal to work on slopes. Automated by means of inclinometers.

available for ID-PLUS and ID-MICRO

POR-17

Recommended kit to use on terraces - option



OBSERVATIONS

REF.



Simultaneous hydraulic lifting of horizontal and vertical bars for using on terraces.

available for ID-PLUS and ID-MICRO

POR-2

Recommended kit for combined use on smart trees and trellis vineyard system



OBSERVATIONS

REF.

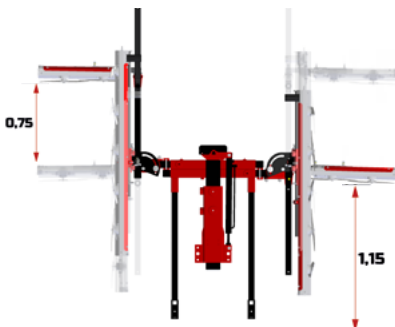

Hydraulic lifting horizontal bar for tree and espalier vineyard.

available for ID-PLUS and ID-MICRO

POR-3

Kit PRO - option



OBSERVATIONS

REF.





Independent hydraulic tilting of vertical and horizontal bars for working on slopes.

available for ID-PLUS and ID-MICRO

POR-4





Connectivity and telemetry Accessories and Options

	DESCRIPTION	OBSERVATIONS	REF.
 	Visualization and telematics monitoring pack *Only available for new machine with ID-PLUS	PRO hydraulic power pack + oil cooler required	FPRO-03
		Only suitable for machines using power from the tractor, without CH.	FPRO-04

Pre-installations and updates Accessories and Options

	DESCRIPTION	OBSERVATIONS	REF.
	CAN compatibility	Only available for machine with oil cooler It allows the remote control compatible with machines that have CAN as standard.	C-CAN-01

Cane trimmer Accessories and Options

	DESCRIPTION	OBSERVATIONS	REF.
	26 Lt Hydraulic power unit type PRO + 35lt pump+ oil cooler	Adaptable to 3 PT	CPRO-1-T
	Pair of additional cutting bars (1 blade)	Inclination adjustment 0°/30 Increases cutting length by 315mm	MCA-P
	3-point coupling kit	Front 3P or reversible tractor	T2P-10
	Plate for front tractor coupling	It will be supplied only if the corresponding form has been correctly filled out	PA-F
	Packaging	Basic	EMB-1
		Airfreight- oceanfreight	EMB-2

Inherent in our DNA

We use technology to create technology.
Our commitment to the digitization and versatility of our equipment has led to the creation of our exclusive ID PLUS system which allows the control of all ID machines through a simple Plug & Play Joystick.



INDUSTRIAS DAVID S.L.U.
C/ Médico Miguel Lucas s/n
CP: 30510, Yecla, Murcia-Spain
Tel.: +34 968 718 119
info@id-david.com

Connect with us.
[instagram.com/iddavid_official](https://www.instagram.com/iddavid_official)
twitter.com/IDdavidslu
[facebook.com/industriasdavid](https://www.facebook.com/industriasdavid)
[linkedin.com/company/id-david](https://www.linkedin.com/company/id-david)
[youtube.com/industriasdavid](https://www.youtube.com/industriasdavid)

www.id-david.com

