

PV-L-R

EN

L-shaped trimmer for vines and hedges

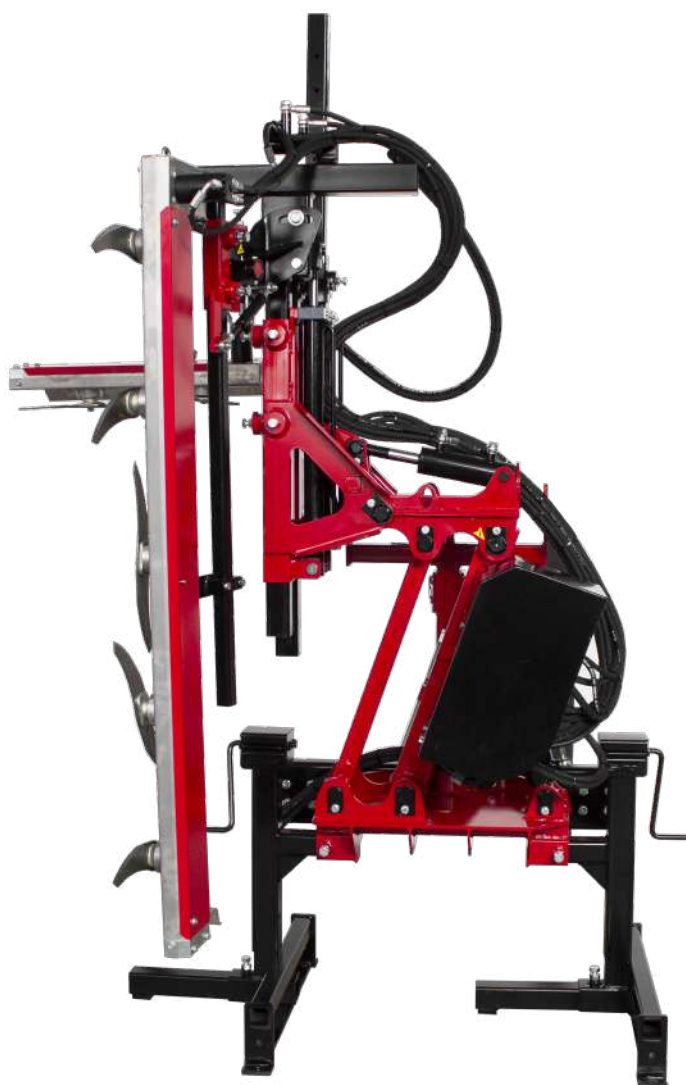

PV-L-R



L-shaped trimmer for vines and hedges. Designed to control canopy growth in small farms or hillside plantations. It allows high working speeds, a clean cut, low maintenance and excellent vision from the cab.

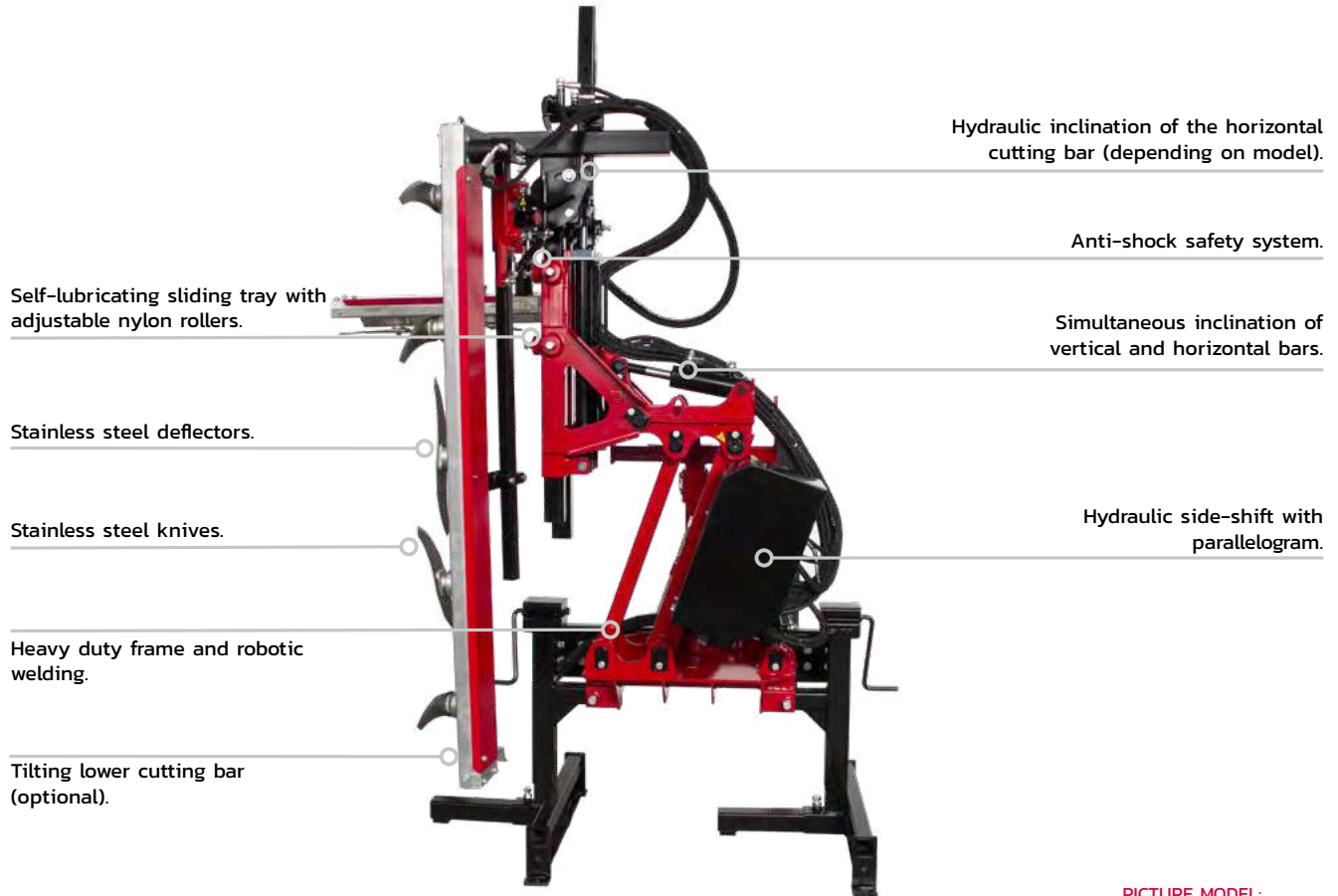

Self-lubricating sliding tray with adjustable nylon rollers.

Stainless steel deflectors.

Stainless steel knives.

Heavy duty frame and robotic welding.

Tilting lower cutting bar (optional).

Hydraulic inclination of the horizontal cutting bar (depending on model).

Anti-shock safety system.

Simultaneous inclination of vertical and horizontal bars.

Hydraulic side-shift with parallelogram.

PICTURE MODEL:
PVL-R-TE-1710

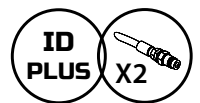
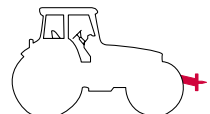
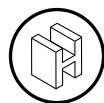
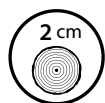

Versatility

- The ID-CONTROL joystick allows to control all the machines manufactured by ID David and equipped with the ID-PLUS or ID-MICRO technology.
- Models adjustable to any kind of plantation system.

Exclusivity

- Exclusive blade design that guarantees a perfect cut.

Effectiveness

- It allows a working speed up to 15 km/h.
- Electrohydraulic system optimized for extremely low power consumption.

Reliability

- Components and materials of high quality.
- Low maintenance (no needs of lubrication in its key parts).
- Cutting elements supported by years of experience in the market.
- Manufacturing experience since 1975.

Safety

- Power transmission to the blades through maintenance-free V-belts.

Sustainability

- An optimal cut improves ventilation and plant health by reducing the use of phytosanitary products.
- The low power required allows the use of small tractors with a lower carbon footprint.
- Sustainable consumption: Equipment designed to be up-to-date and have a long service life.

Standard Equipment

- Anti-shock safety system.
- Sliding tray "no grease" with adjustable nylon wheels.
- Hydraulic lifting.
- Hydraulic inclination.
- Hydraulic parallelogram lateral displacement.
- Stainless steel blade cutting bars.
- Storage foot.
- Adaptable standard plate to tractor (frontal).
- Lateral support rods.

Remote control type

ID-PLUS

- It includes ID-CONTROL multifunction joystick.
- Includes an electronic microcontroller: allows software updates at any time.
- Max 2-3 additional electro-hydraulic functions (depending on model).
- Includes a modular electro-hydraulic system: it allows to increase the number of electro-hydraulic functions.

ID-MICRO



- ! Not included the ID-CONTROL multifunction joystick.
- Only for customers who already have the ID-CONTROL multifunction joystick.
- Includes an electronic microcontroller: allows software updates at any time.
- Max 2-3 additional electro-hydraulic functions (depending on model).
- Includes a modular electro-hydraulic system: it allows to increase the number of electro-hydraulic functions.

	ID-PLUS	ID-MICRO			
	REF.	REF.	A (m)	B (m)	X (m)
PV-L-R L SHAPE CANE TRIMMER FOR VINEYARD AND OLIVES TREES CUT, EXTENSION, MODULE TILT, MODULE LIFT	PVL-R-EP-1710-1	PVL-R-EP-1710-2	1,70	0,90	2,20-2,80
 CUT, EXTENSION, MODULE TILT, MODULE LIFT, HORIZONTAL BAR LIFT	PVL-R-TE-1710-1	PVL-R-TE-1710-2	1,70	0,90	1,50-2,60
 CUT, EXTENSION, MODULE TILT, MODULE LIFT, HORIZONTAL BAR LIFT	PVL-R-LA-1710-1	PVL-R-LA-1710-2	1,70	0,90	2,20-2,80

PV-L

Prepruning, pruning and leaf stripping

Technical details

		X	Y	Z	A	B			L	W	H
	REF.	m	m	m	m	m	kg	HP	m	m	m
PV-L-R	PVL-R-EP-1710	2,20-2,80	0,55-1,40	1,40-2,20	1,70	0,90	380	60	1,40	1,10	2,20
	PVL-R-TE-1710	1,50-2,60	0,55-1,40	1,40-2,20	1,70	0,90	400	60	1,40	1,10	2,20
	PVL-R-LA-1710	2,20-2,80	0,55-1,40	1,40-2,20	1,70	0,90	400	60	1,40	1,10	2,20

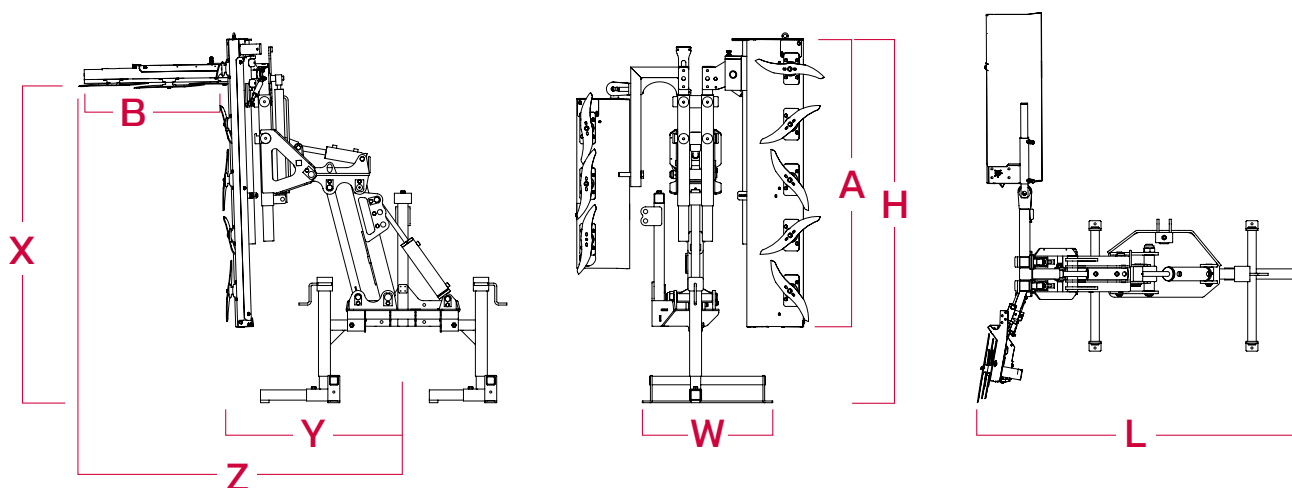

Tractor mounting



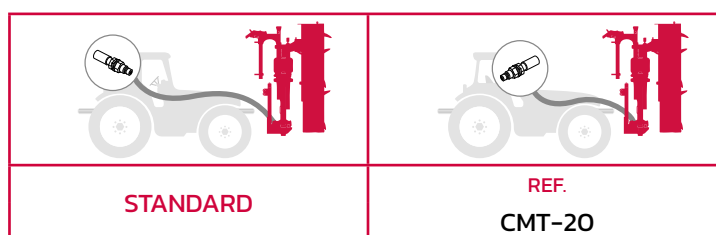

Tractor connection and assembling



* 3PH and tractor assembly plate not included.





Connectivity and telemetry Accessories and Options

	DESCRIPTION	OBSERVATIONS	REF.
 	Visualization and telematics monitoring pack *Only available for new machine with ID-PLUS	PRO hydraulic power pack + oil cooler required Only suitable for machines using power from the tractor, without CH.	FPRO-03 FPRO-04

Pre-installations and updates Accessories and Options

	DESCRIPTION	OBSERVATIONS	REF.
	CAN compatibility	Only available for machine with oil cooler It allows the remote control compatible with machines that have CAN as standard.	C-CAN-01

Cane trimmer Accessories and Options

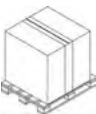
	DESCRIPTION	OBSERVATIONS	REF.
	26 Lt Hydraulic power unit type PRO + 35lt pump+ oil cooler	Adaptable to 3 PT	CPRO-1-T
	Additional cutting bar- Right (1 blade)	Inclination adjustment 0°/30° Increases cutting length by 315mm	MCA-D
	3-point coupling kit	Front 3P or reversible tractor	T2P-10
	Plate for front tractor coupling	It will be supplied only if the corresponding form has been correctly filled out	PA-F
	Packaging	Basic	EMB-1
		Airfreight- oceanfreight	EMB-2

Inherent in our DNA

We use technology to create technology.
Our commitment to the digitization and versatility of our equipment has led to the creation of our exclusive ID PLUS system which allows the control of all ID machines through a simple Plug & Play Joystick.



INDUSTRIAS DAVID S.L.U.
C/ Médico Miguel Lucas s/n
CP: 30510, Yecla, Murcia-Spain
Tel.: +34 968 718 119
info@id-david.com

Connect with us.
[instagram.com/iddavid_official](https://www.instagram.com/iddavid_official)
twitter.com/IDdavidslu
[facebook.com/industriasdavid](https://www.facebook.com/industriasdavid)
[linkedin.com/company/id-david](https://www.linkedin.com/company/id-david)
[youtube.com/industriasdavid](https://www.youtube.com/industriasdavid)

www.id-david.com

